



**VILLAGE OF LINDENHURST**  
**Regular Village Board Meeting**  
**Monday, February 10, 2025**  
**7:00 p.m.**

- I. Call to Order
- II. Pledge of Allegiance
- III. Approval of the Minutes from the Regular Village Board Meeting of January 27, 2025
- IV. Treasurer's Report for January 2025
- V. Bills Presented for Payment
- VI. Board and Staff Reports
- VII. Public Comment on Agenda Items
- VIII. New Business
  - A. Resolution 25-2-2308R: Approving and Making a Determination on Executive Session Meeting Minutes and Verbatim Recordings
  - B. Approval: Request from S.T.U.D.Y.S. Ministries (656 Bridgeport Terrace) for Relief from Signage Code to Install an LED Sign
  - C. Approval: Public Works Wastewater Treatment Facility Building Roof Repairs – Waukegan Roofing - \$79,695.
  - D. Approval: Public Works 5-Ton Truck Replacement Purchase - \$222,728
- IX. Public Comment
- X. Executive Session
- XI. Adjournment

**Rules for Public Comment:** The Village of Lindenhurst welcomes comments from the public during the designated sections of the Village Board meeting. We ask that you keep your comments respectful, civil, and constructive to matters of public policy. Those wishing to comment will be limited to three (3) minutes per person and the total time allotted for public comment will be thirty (30) minutes. The Chair will recognize speakers and may deny someone who has previously addressed the Board an additional opportunity to speak. (VOL Village Code §30.22)

**VILLAGE OF LINDENHURST**  
**2301 E Sand Lake Road**

**Regular Village Board Meeting Minutes**  
**January 27, 2025**  
**7:00pm**

---

---

**I. Call to Order**

- A. Mayor Marturano called the Regular Village Board Meeting to order at 7:00pm.

**II. Roll Call**

- A. Present were Mayor Dominic Marturano, Trustees Pat Dickson, Pat Dunham, Patty Chybowski, Dawn Suchy, Heath Rosten, and Ron Grace.
- B. Also in attendance were Village Administrator Clay Johnson, Village Attorney Julie Tappendorf, Police Chief Tom Jones, Operations Director Kevin Klahs, Assistant to the Village Administrator Karleen Long, Utility Systems Manager Charles Hernandez, and Village Clerk Melissa Forsberg.

**III. Pledge of Allegiance**

**IV. Approval of Minutes**

- A. Minutes from the Regular Village Board Meeting of January 13, 2025 were presented for approval.
- B. Trustee Grace made a motion, seconded by Trustee Chybowski, to approve the minutes from the Regular Village Board Meeting of January 13, 2025 as presented.
1. Voice Vote  
Aye - 5  
Nay - 0  
Abstain - 1  
Motion carried.

**V. Bills Presented for Payment**

- A. Trustee Dunham made a motion, seconded by Trustee Suchy, to approve the second set of bills for the month of January presented for payment in the amount of \$335,212.75 for invoices due on or before January 27, 2025.
1. Roll Call  
Aye – 6 Trustees Dickson, Dunham, Chybowski, Suchy, Rosten, Grace  
Nay – 0  
Motion carried.

**VI. Board & Staff Reports**

- A. Mayor Marturano reported with the new state congress in session, State Representative Anthony Deluca has written and will sponsor HB 1282 for the return of Local Government Distributive Fund (LGDF) dollars to be paid in full by 2031.
- B. Village Administrator Johnson spoke about the first open house for the Grand Avenue Street scape and Design. The second open house will be February 24, 2025 from 5:00-6:45pm.
- C. Assistant to the Village Administrator Long spoke about the first upcoming Lindenhurst Restaurant week to take place February 10-16, 2025.
- D. Police Chief Jones took a moment to thank and recognize staff, residents, and the Village Board for providing him the opportunity to be Chief over the last 10 years. Mayor Marturano then presented Chief Jones with a plaque recognizing his years of service. Thank you Chief Jones and enjoy your retirement.

**VII. Public Comment on Agenda Items**

- A. None.

**VIII. New Business**

- A. Appointment: Mayoral Appointment to Acting Chief of Police
  - 1. The retirement of Chief Jones is set to take place January 31, 2025. The Police Department requires a leader to provide direction, while the Village continues its search for a new Police Chief. Commander Eric Senica has both the traits and leadership ability to serve in this roll.
  - 2. Commander Senica has extensive experience within his 26-year law enforcement career with the Lindenhurst Police Department. Additionally, Commander Senica has worked as a part-time Lake County Forest Preserve Police Officer, and was an Adjunct Instructor for McHenry County College teaching criminal justice courses from 2006-2019. Commander Senica also holds the following degrees:
    - a. Columbia College - B.S. in Individual Studies with an Emphasis in Criminal Justice
    - b. Webster University - M.A. in Management
    - c. Northwestern University School of Police Staff and Command graduate.
  - 3. It is recommended Commander Senica receive a 10% salary increase during the course of this temporary position.
  - 4. Trustee Grace made a motion, seconded by Trustee Suchy to approve the appointment of Commander Eric Senica to Acting Chief of Police through April 30, 2025 or until a permanent Chief can be appointed. The appointment comes with an associated 10% increase in salary until such time a permanent Chief is named.
    - a. Roll Call
      - Aye - 6 Trustees Dickson, Dunham, Chybowski, Suchy, Rosten, Grace
      - Nay - 0

Motion carried.

- B. Presentation and Discussion: Grand Avenue Street scape and Design Update
1. Teska and Village staff hosted an open house prior to the Village Board meeting. They were looking for input from the public on the draft plans and architectural design recommendations for the Grand Avenue corridor.
  2. Thank you to the following group of staff, business owners, and residents for providing Teska their thoughts as to the future of the Grand Avenue corridor:
    - a. Anita Archambeau - Economic Development Specialist
    - b. Karleen Long - Assistant to the Village Administrator
    - c. Kevin Klahs - Director of Operations
    - d. Clay Johnson - Village Administrator
    - e. David Mohr - Executive Director, Lindenhurst Park District
    - f. Mick Jacobsen - Executive Director, Lake Villa District Library
    - g. Andrew Aswad - Plan Commission Chairman, resident
    - h. Yami Hu - Owner, 3 Legged Coffee Brewery
    - i. Jeremy Scherbert - COO, 3 Legged Coffee Brewery
    - j. Mary Erl - Grand Avenue resident, former Chamber of Commerce President
  3. Teska provided community feedback received during the open house and explained how they will proceed going into the second open house.

- C. Discussion: Video Gaming Regulations
1. In November 2024, it was suggested video gaming regulations may need to be reviewed as to what is considered a video gaming café. After much discussion amongst the Village Board, it was the consensus of the Board to leave the regulation as it currently stands.

**IX. Public Comment**

- A. None.

**X. Executive Session**

- A. Mayor Marturano informed the Board and Public that the purpose of the Executive Session was to address Statutorily required review of prior executive session minutes as per 5 ILCS 120/2(c)(21).
- B. Trustee Chybowski made a motion, seconded by Trustee Suchy to move into Executive Session for the review of prior executive session minutes pursuant to 5 ILCS 120/2(c)(21).
1. Roll Call  
Aye - 6 Trustees Dickson, Dunham, Chybowski, Suchy, Rosten, Grace  
Nay - 0  
Motion carried.
- C. The regular Village Board meeting moved out of regular session at 8:18pm.
- D. Return to Regular Session
1. The Regular Board Meeting reconvened at 8:19pm.

XI. **Adjournment**

- A. Trustee Chybowski made a motion, seconded by Trustee Suchy to adjourn the meeting.
  - 1. Voice Vote
    - Aye - 6
    - Nay - 0
    - Motion carried.
  - 2. The meeting was adjourned at 8:20pm.

Date approved \_\_\_\_\_

\_\_\_\_\_  
Dominic Marturano, Mayor

\_\_\_\_\_  
Melissa Forsberg, Village Clerk

CASH SUMMARY BY FUND FOR VILLAGE OF LINDENHURST  
 FROM 01/01/2025 TO 01/31/2025  
 FUND: ALL FUNDS  
 CASH AND INVESTMENT ACCOUNTS

Fund	Description	Beginning Balance 01/01/2025	Total Debits	Total Credits	Ending Balance 01/31/2025
01	GENERAL FUND	5,333,859.08	523,331.37	499,114.07	5,358,076.38
06	I.M.R.F./F.I.C.A. 06	276,222.17	1,214.28	13,800.19	263,636.26
11	IT FUND	74,439.85	14,207.74	17,347.42	71,300.17
14	LIABILITY INSURANCE 14	87,342.91	0.00	118,260.80	(30,917.89)
15	MOTOR FUEL TAX 15	2,468,497.70	61,943.09	0.00	2,530,440.79
19	CONTROLLED SUBSTANCE ACT 19	4,547.51	0.00	0.00	4,547.51
21	COMMUNITY CAPITAL	4,315,055.50	31,803.37	108,378.06	4,238,480.81
22	DUI SB 740 FUND 22	7,447.80	44.19	1,939.00	5,552.99
23	PRISON REVIEW AGENCY FUND 23	9,968.29	0.00	0.00	9,968.29
24	MISCELLANEOUS ESCROW 24	421,912.16	1,000.00	5,043.28	417,868.88
25	SHOP WITH A COP FUND 25	6,412.81	4,901.50	4,901.50	6,412.81
27	CURRENCY SEIZURE 27	5,399.56	0.00	0.00	5,399.56
30	REFUSE & RECYCLING 30	248,366.04	95,986.50	130,841.52	213,511.02
40	ECONOMIC DEVELOPMENT FUND	221,889.79	0.00	5,838.60	216,051.19
41	GRAND AVENUE TIF FUND	166,605.76	0.00	90.00	166,515.76
46	SPECIAL SERVICE AREA 4 - 46	23,994.09	0.00	23,994.09	0.00
50	VEHICLE REPLACEMENT FUND 50	414,553.64	0.00	9,475.23	405,078.41
60	UTILITY FUND 60	1,420,404.51	366,525.25	378,176.27	1,408,753.49
61	WATER/SEWER CAPITAL FUND 61	1,753,605.50	95,583.58	146,014.65	1,703,174.43
89	SANITARY DISTRICT	3,635.82	57.40	3,635.82	57.40
	TOTAL - ALL FUNDS	17,264,160.49	1,196,598.27	1,466,850.50	16,993,908.26

Fund	Department	Line Item	Item Description	Amount
<b>AEP ENERGY</b>				
GENERAL FUND	PUBLIC WORKS	STREET & TRAFFIC CTR LIGHTING	ELECTRIC SERVICE STREET LIGHTS -	489.64
			<b>Vendor Total:</b>	<b>489.64</b>
<b>ANTIOCH AUTO PARTS</b>				
GENERAL FUND	PUBLIC WORKS	VEHICLE & EQUIPMENT SUPPLIES	FLUID EVACUATE REPL.	109.44
UTILITY FUND 60	SEWER & WATER ADMINISTRATION	VEHICLE & EQUIPMENT SUPPLIES	FLUID EVACUATE REPL.	72.96
			<b>Vendor Total:</b>	<b>182.40</b>
<b>AWARDS BY KAYDAN</b>				
GENERAL FUND	ADMINISTRATION	CONTINGENCIES	RETIREMENT AWARD - T. JONES	64.50
			<b>Vendor Total:</b>	<b>64.50</b>
<b>BAXTER &amp; WOODMAN, INC</b>				
COMMUNITY CAPITAL	ADMINISTRATION	GREEN/SUSTAINABILITY IMPROVEMENT	ROSETREE OUTFALL DESIGN ENGINEEF	6,900.00 D
			<b>Vendor Total:</b>	<b>6,900.00</b>
<b>BRAVO SERVICES, INC</b>				
GENERAL FUND	BUILDING & GROUNDS	CLEANING CONTRACT	JANUARY 2025 CUSTODIAL SERVICES	798.94 D
GENERAL FUND	POLICE	BUILDING & GROUNDS MTCE POLICE	JANUARY 2025 CUSTODIAL SERVICES	798.70 D
UTILITY FUND 60	SEWER & WATER ADMINISTRATION	CUSTODIAL SERVICE	JANUARY 2025 CUSTODIAL SERVICES	798.70 D
			<b>Vendor Total:</b>	<b>2,396.34</b>
<b>BS&amp;A SOFTWARE</b>				
IT FUND		SOFTWARE SUPPORT/LICENSING	ANNUAL SERVICE 02/01/25 - 02/01/	2,144.00
			<b>Vendor Total:</b>	<b>2,144.00</b>
<b>CENTRAL LAKE COUNTY J.A.W.A</b>				
UTILITY FUND 60	WATER	CLCJAWA WATER SUPPLY PURCHASE	CLCJAWA WATER - USAGE FOR JANUAF	78,303.15
			<b>Vendor Total:</b>	<b>78,303.15</b>
<b>CHRISTOPHER B. BURKE ENGINEERING</b>				
COMMUNITY CAPITAL	ADMINISTRATION	LAKE SHORE DRIVE ENG DESIGN	MISC ENGINEERING ASSISTANCE	62.50 D
			<b>Vendor Total:</b>	<b>62.50</b>
<b>CINTAS</b>				
GENERAL FUND	PUBLIC WORKS	UNIFORMS	FIRST AID REFILL - PW	21.20
UTILITY FUND 60	SEWER & WATER ADMINISTRATION	UNIFORMS	FIRST AID REFILL - PW	31.81
GENERAL FUND	PUBLIC WORKS	UNIFORMS	UNIFORMS	30.81
UTILITY FUND 60	SEWER & WATER ADMINISTRATION	UNIFORMS	UNIFORMS	46.22
GENERAL FUND	PUBLIC WORKS	UNIFORMS	CORRECTION FROM NOV/DEC	(0.01)
GENERAL FUND	PUBLIC WORKS	UNIFORMS	FLOOR MATS PW/UNIFORMS	31.79
UTILITY FUND 60	SEWER & WATER ADMINISTRATION	UNIFORMS	FLOOR MATS PW/UNIFORMS	52.99
GENERAL FUND	PUBLIC WORKS	CUSTODIAL SERVICE	FLOOR MATS PW/UNIFORMS	71.53
UTILITY FUND 60	SEWER & WATER ADMINISTRATION	CUSTODIAL SERVICE	FLOOR MATS PW/UNIFORMS	108.62
GENERAL FUND	POLICE	BUILDING & GROUNDS MTCE POLICE	MATS FOR PD	109.94
GENERAL FUND	BUILDING & GROUNDS	CLEANING CONTRACT	MATS FOR VH	42.30
			<b>Vendor Total:</b>	<b>547.20</b>
<b>CLARK BAIRD SMITH LLP</b>				
GENERAL FUND	ADMINISTRATION	LEGAL EXPENSES	LEGAL SERVICES	656.25
			<b>Vendor Total:</b>	<b>656.25</b>
<b>COMCAST CABLE</b>				
IT FUND		TELEPHONE/INTERNET	INTERNET VH/PD	264.90
IT FUND		TELEPHONE/INTERNET	VH, PD & PW TELEPHONE - JANUARY	993.87
			<b>Vendor Total:</b>	<b>1,258.77</b>
<b>COMMONWEALTH EDISON</b>				
GENERAL FUND	PUBLIC WORKS	STREET & TRAFFIC CTR LIGHTING	ELECTRIC STREET LIGHTS	165.47
			<b>Vendor Total:</b>	<b>165.47</b>
<b>COMPLETE OFFICE OF WISCONSIN</b>				
UTILITY FUND 60	SEWER & WATER ADMINISTRATION	OPERATING SUPPLIES	OPERATING SUPPLIES	26.18 D
GENERAL FUND	ADMINISTRATION	OPERATING SUPPLIES	OPERATING SUPPLIES	6.54 D
REFUSE & RECYCLING 30		GARBAGE CONTRACTUAL SERVICES	OPERATING SUPPLIES	6.54 D
GENERAL FUND	POLICE	OPERATING SUPPLIES	OPERATING SUPPLIES	26.18 D
UTILITY FUND 60	SEWER & WATER ADMINISTRATION	OPERATING SUPPLIES	OPERATING SUPPLIES	6.96 D
GENERAL FUND	ADMINISTRATION	OPERATING SUPPLIES	OPERATING SUPPLIES	1.74 D
REFUSE & RECYCLING 30		GARBAGE CONTRACTUAL SERVICES	OPERATING SUPPLIES	1.74 D
GENERAL FUND	POLICE	OPERATING SUPPLIES	OPERATING SUPPLIES	6.95 D
UTILITY FUND 60	SEWER & WATER ADMINISTRATION	OPERATING SUPPLIES	OPERATING SUPPLIES	13.22 D

		BOTH OPEN AND PAID			
Fund	Department	Line Item	Item Description	Amount	
GENERAL FUND	ADMINISTRATION	OPERATING SUPPLIES	OPERATING SUPPLIES	3.30	D
REFUSE & RECYCLING 30		GARBAGE CONTRACTUAL SERVICES	OPERATING SUPPLIES	3.30	D
GENERAL FUND	POLICE	OPERATING SUPPLIES	OPERATING SUPPLIES	13.23	D
UTILITY FUND 60	SEWER & WATER ADMINISTRATION	OPERATING SUPPLIES	OPERATING SUPPLIES	38.23	D
GENERAL FUND	ADMINISTRATION	OPERATING SUPPLIES	OPERATING SUPPLIES	9.56	D
REFUSE & RECYCLING 30		GARBAGE CONTRACTUAL SERVICES	OPERATING SUPPLIES	9.56	D
GENERAL FUND	POLICE	OPERATING SUPPLIES	OPERATING SUPPLIES	38.22	D
UTILITY FUND 60	SEWER & WATER ADMINISTRATION	OPERATING SUPPLIES	OPERATING SUPPLIES	72.27	D
GENERAL FUND	ADMINISTRATION	OPERATING SUPPLIES	OPERATING SUPPLIES	18.07	D
REFUSE & RECYCLING 30		GARBAGE CONTRACTUAL SERVICES	OPERATING SUPPLIES	18.07	D
GENERAL FUND	POLICE	OPERATING SUPPLIES	OPERATING SUPPLIES	72.26	D
UTILITY FUND 60	SEWER & WATER ADMINISTRATION	OPERATING SUPPLIES	OPERATING SUPPLIES	9.64	D
GENERAL FUND	ADMINISTRATION	OPERATING SUPPLIES	OPERATING SUPPLIES	2.41	D
REFUSE & RECYCLING 30		GARBAGE CONTRACTUAL SERVICES	OPERATING SUPPLIES	2.41	D
GENERAL FUND	POLICE	OPERATING SUPPLIES	OPERATING SUPPLIES	9.64	D
UTILITY FUND 60	SEWER & WATER ADMINISTRATION	OPERATING SUPPLIES	OPERATING SUPPLIES	12.15	D
GENERAL FUND	ADMINISTRATION	OPERATING SUPPLIES	OPERATING SUPPLIES	3.04	D
REFUSE & RECYCLING 30		GARBAGE CONTRACTUAL SERVICES	OPERATING SUPPLIES	3.04	D
GENERAL FUND	POLICE	OPERATING SUPPLIES	OPERATING SUPPLIES	12.15	D
		<b>Vendor Total:</b>		<b>446.60</b>	
<b>DATA INTEGRATORS, INC.</b>					
UTILITY FUND 60	SEWER & WATER ADMINISTRATION	UTILITY BILLING CONTRACT	UB PROCESSING/MAILING & UB POSTA	1,179.37	D
REFUSE & RECYCLING 30		GARBAGE CONTRACTUAL SERVICES	UB PROCESSING/MAILING & UB POSTA	294.84	D
		<b>Vendor Total:</b>		<b>1,474.21</b>	
<b>DEKIND COMPUTER CONSULTANTS</b>					
IT FUND		COMPUTER SERVICES	CYBER SECURITY TRAINING - JANUAF	667.00	D
IT FUND		COMPUTER SERVICES	OVER CONTRACT HOURS FOR	190.00	D
IT FUND		COMPUTER SERVICES	MARCH 2025 MONTHLY IT SUPPORT SE	4,422.54	D
GENERAL FUND	POLICE	CONTRACT COMPUTER SERVICES	MARCH 2025 MONTHLY IT SUPPORT SE	2,805.00	D
		<b>Vendor Total:</b>		<b>8,084.54</b>	
<b>FERGUSON WATERWORKS #2516</b>					
UTILITY FUND 60	SEWER & WATER ADMINISTRATION	SOFTWARE SUPPORT/LICENSING	ANNUAL NEPTUNE AMR SOFTWARE	11,587.31	D
		<b>Vendor Total:</b>		<b>11,587.31</b>	
<b>FIRST AMERICAN BANK</b>					
REFUSE & RECYCLING 30		MERCHANT FEES	CREDIT CARD FEES - JANUARY 2025	727.17	
UTILITY FUND 60	SEWER & WATER ADMINISTRATION	MERCHANT FEES	CREDIT CARD FEES - JANUARY 2025	2,908.70	
REFUSE & RECYCLING 30		GARBAGE CONTRACTUAL SERVICES	LOCK BOX FEES - JANUARY 2025	99.33	
UTILITY FUND 60	SEWER & WATER ADMINISTRATION	LOCKBOX	LOCK BOX FEES - JANUARY 2025	397.34	
		<b>Vendor Total:</b>		<b>4,132.54</b>	
<b>FIRST AMERICAN BANK</b>					
SHOP WITH A COP FUND 25	POLICE	SHOP WITH A COP EXPENSES	ANTIOCH PIZZA - SHOP WITH A COP	300.00	
GENERAL FUND	POLICE	MISC CONTRACTUAL SERVICES	LEXIS NEXIS	200.00	
IT FUND		SOFTWARE SUPPORT/LICENSING	ZOOM VIDEO COMMUNICATIONS	15.99	
GENERAL FUND	ADMINISTRATION	TRAINING & CONFERENCE	DRURY PLAZA HOTEL - JOHNSON CONF	155.62	
GENERAL FUND	ADMINISTRATION	TRAINING & CONFERENCE	DRURY PLAZA HOTEL - LONG CONFERE	155.62	
GENERAL FUND	ADMINISTRATION	TRAINING & CONFERENCE	ICMA ONLINE - JOHNSON & LONG CON	688.00	
GENERAL FUND	ADMINISTRATION	NEWS LETTER	CONSTANT CONTACT	63.00	
IT FUND		EQUIPMENT MAINTENANCE	PITNEY BOWES - ADDITIONAL METER	100.00	
GENERAL FUND	POLICE	TRAINING & CONFERENCES	AMERICAN HEART SHOP - CPR TRAINI	478.50	
GENERAL FUND	POLICE	OPERATING SUPPLIES	HOBBY LOBBY - PICTURE FRAMES PD	159.95	
GENERAL FUND	POLICE	OPERATING SUPPLIES	HOBBY LOBBY - RETURNED PICTURE F	(27.99)	
GENERAL FUND	POLICE	MISC CONTRACTUAL SERVICES	LEXIS NEXIS	200.00	
GENERAL FUND	ADMINISTRATION	CONTINGENCIES	DAMASHKEY - VH HOLIDAY LUNCH	127.87	
UTILITY FUND 60	SEWER & WATER ADMINISTRATION	MEMBERSHIP FEES	APWA.NET - MEMBERSHIP FEES	795.00	
GENERAL FUND	ADMINISTRATION	MISC EQUIPMENT	HARTFORD TECHNOLOGY - SCANNER RE	700.04	
		<b>Vendor Total:</b>		<b>4,111.60</b>	
<b>GRANITE TELECOMMUNICATIONS</b>					
GENERAL FUND	POLICE	TELEPHONE	TELEPHONE - PD	273.59	D
UTILITY FUND 60	SEWER & WATER ADMINISTRATION	TELEPHONE	TELEPHONE - PW	796.98	D
		<b>Vendor Total:</b>		<b>1,070.57</b>	

Fund	Department	Line Item	Item Description	Amount
<b>GREAT AMERICAN TIRE &amp; AUTO</b>				
GENERAL FUND	POLICE	VEHICLE SERVICE	#86 - TIRE REPAIR	25.20
			<b>Vendor Total:</b>	<b>25.20</b>
<b>GROOT INDUSTRIES, INC</b>				
REFUSE & RECYCLING 30		GROOT CONTRACT	GROOT BILLING CONTRACT	107,761.05 D
			<b>Vendor Total:</b>	<b>107,761.05</b>
<b>HAWKINS, INC.</b>				
UTILITY FUND 60	WATER	CHLORINE GAS & POLYPHOSPHATE	HYPO - STAND BY WELLS	534.86 D
			<b>Vendor Total:</b>	<b>534.86</b>
<b>HINCKLEY SPRINGS</b>				
GENERAL FUND	ADMINISTRATION	OPERATING SUPPLIES	WATER FOR VH/PD	42.47
GENERAL FUND	POLICE	OPERATING SUPPLIES	WATER FOR VH/PD	124.23
			<b>Vendor Total:</b>	<b>166.70</b>
<b>ILLINOIS EPA</b>				
UTILITY FUND 60	SEWER & WATER ADMINISTRATION	IEPA LOAN - PHASE I	IEPA LOAN - PHASE I	202,497.49
UTILITY FUND 60	SEWER & WATER ADMINISTRATION	IEPA LOAN - PHASE II	IEPA LOAN - PHASE II	333,833.22
			<b>Vendor Total:</b>	<b>536,330.71</b>
<b>IMRF VILLAGE OF LINDENHURST</b>				
I.M.R.F./F.I.C.A. 06	ADMINISTRATION	GENERAL ADMIN IMRF	VILLAGE OF LINDENHURST IMRF - JA	9,035.75
UTILITY FUND 60	SEWER & WATER ADMINISTRATION	SEWER/WATER IMRF	VILLAGE OF LINDENHURST IMRF - JA	9,224.00
REFUSE & RECYCLING 30		IMRF CONTRIBUTION	VILLAGE OF LINDENHURST IMRF - JA	564.73
			<b>Vendor Total:</b>	<b>18,824.48</b>
<b>IPBC</b>				
GENERAL FUND	ADMINISTRATION	HOSPITALIZATION	EMPLOYER CONTRIBUTION - FEBRUARY	3,431.34
GENERAL FUND	ENGINEERING & BUILDING	HOSPITALIZATION	EMPLOYER CONTRIBUTION - FEBRUARY	880.63
GENERAL FUND	POLICE	HOSPITALIZATION	EMPLOYER CONTRIBUTION - FEBRUARY	30,145.40
REFUSE & RECYCLING 30		HOSPITALIZATION	EMPLOYER CONTRIBUTION - FEBRUARY	2,512.17
GENERAL FUND	PUBLIC WORKS	HOSPITALIZATION	EMPLOYER CONTRIBUTION - FEBRUARY	2,785.40
UTILITY FUND 60	SEWER & WATER ADMINISTRATION	HOSPITALIZATION	EMPLOYER CONTRIBUTION - FEBRUARY	8,690.16
GENERAL FUND	ADMINISTRATION	HOSPITALIZATION	RETIREE CONTRIBUTION REFUNDED	(149.70)
GENERAL FUND	ENGINEERING & BUILDING	HOSPITALIZATION	RETIREE CONTRIBUTION REFUNDED	(149.70)
GENERAL FUND	POLICE	HOSPITALIZATION	RETIREE CONTRIBUTION REFUNDED	(149.70)
REFUSE & RECYCLING 30		HOSPITALIZATION	RETIREE CONTRIBUTION REFUNDED	(149.70)
GENERAL FUND	PUBLIC WORKS	HOSPITALIZATION	RETIREE CONTRIBUTION REFUNDED	(149.70)
UTILITY FUND 60	SEWER & WATER ADMINISTRATION	HOSPITALIZATION	RETIREE CONTRIBUTION REFUNDED	(149.70)
			<b>Vendor Total:</b>	<b>47,546.90</b>
<b>KRISTIN RAYOME</b>				
GENERAL FUND	POLICE	OPERATING SUPPLIES	REIMBURSEMENT - CHEIF'S RETIREME	27.26
			<b>Vendor Total:</b>	<b>27.26</b>
<b>LAKE COUNTY DOOR COMPANY</b>				
GENERAL FUND	BUILDING & GROUNDS	REPAIRS & MAINTENANCE	WATER DEPT DOOR REPAIR	140.00
			<b>Vendor Total:</b>	<b>140.00</b>
<b>LAKESIDE INTERNATIONAL LLC</b>				
GENERAL FUND	PUBLIC WORKS	CONTRACT VEHICLE REPAIRS	TRK 55 EGR SYSTEM REPAIR	7,177.98
UTILITY FUND 60	SEWER & WATER ADMINISTRATION	CONTRACT VEHICLE REPAIRS	TRK 55 EGR SYSTEM REPAIR	4,785.33
			<b>Vendor Total:</b>	<b>11,963.31</b>
<b>LINDE GAS &amp; EQUIPMENT INC.</b>				
GENERAL FUND	PUBLIC WORKS	VEHICLE & EQUIPMENT SUPPLIES	GAS CYLINDERS	48.75 D
			<b>Vendor Total:</b>	<b>48.75</b>
<b>LINDENHURST SANITARY DISTRICT</b>				
SANITARY DISTRICT		SANITARY DIST CONNECTION FEE	JANUARY 2025 - IN LIEU OF TAXES	57.40
			<b>Vendor Total:</b>	<b>57.40</b>
<b>LINDENHURST, VILLAGE OF</b>				
GENERAL FUND	ADMINISTRATION	CONTINGENCIES	PETTY CASH REIMBURSEMENT - ICE F	25.64
			<b>Vendor Total:</b>	<b>25.64</b>
<b>MANHARD CONSULTING LTD</b>				
MISCELLANEOUS ESCROW 24		DEVELOPER DEPOSITS	ESCROW - BRIARGATE	2,002.25 D
MISCELLANEOUS ESCROW 24		DEVELOPER DEPOSITS	ESCROW - LENNAR	217.50 D
			<b>Vendor Total:</b>	<b>2,219.75</b>
<b>MCCULLOUGH IMPLEMENT</b>				

VILLAGE OF LINDENHURST Treasurer's Report  
 EXP CHECK RUN DATES 01/28/2025 - 02/10/2025  
 BOTH JOURNALIZED AND UNJOURNALIZED

		BOTH OPEN AND PAID		
Fund	Department	Line Item	Item Description	Amount
GENERAL FUND	PUBLIC WORKS	CONTRACT VEHICLE REPAIRS	TRK 20 ANNUAL SERVICE	974.98
UTILITY FUND 60	SEWER & WATER ADMINISTRATION	CONTRACT VEHICLE REPAIRS	TRK 20 ANNUAL SERVICE	649.99
			<b>Vendor Total:</b>	<b>1,624.97</b>
<b>MENARDS - ANTIOCH</b>				
GENERAL FUND	PUBLIC WORKS	OPERATING SUPPLIES	CAULK	8.76 D
UTILITY FUND 60	WATER	REPAIRS & MAINTENANCE	WELL 6 PIPING	69.35 D
GENERAL FUND	BUILDING & GROUNDS	REPAIRS & MAINTENANCE	PD SUMP PUMP	39.89 D
GENERAL FUND	BUILDING & GROUNDS	REPAIRS & MAINTENANCE	PD SUMP PUMP REPL.	37.84 D
GENERAL FUND	PUBLIC WORKS	OPERATING SUPPLIES	MOUSE TRAPS	5.98 D
GENERAL FUND	PUBLIC WORKS	OPERATING SUPPLIES	MAILBOX SUPPLIES	282.49 D
GENERAL FUND	POLICE	OPERATING SUPPLIES	OPERATING SUPPLIES	17.47 D
GENERAL FUND	POLICE	CONTINGENCY	OPERATING SUPPLIES	288.99 D
GENERAL FUND	POLICE	VEHICLE SERVICE	VEHICLE SERVICES	18.75 D
			<b>Vendor Total:</b>	<b>769.52</b>
<b>MGN LOCK</b>				
COMMUNITY CAPITAL	ADMINISTRATION	VILLAGE FACILITIES AND EQUIPMENT	FACILITY DOOR REPAIRS	6,181.00
			<b>Vendor Total:</b>	<b>6,181.00</b>
<b>MIDWEST OPERATING ENGINEERS</b>				
GENERAL FUND	PUBLIC WORKS	HOSPITALIZATION	MARCH 2025 PW INSURANCE	5,978.80
UTILITY FUND 60	SEWER & WATER ADMINISTRATION	HOSPITALIZATION	MARCH 2025 PW INSURANCE	8,968.20
			<b>Vendor Total:</b>	<b>14,947.00</b>
<b>MOTOROLA SOLUTIONS, INC.</b>				
GENERAL FUND	POLICE	MISC CONTRACTUAL SERVICES	VIDEO CAMERA WARRANTY	5,395.00 D
			<b>Vendor Total:</b>	<b>5,395.00</b>
<b>NORTH SHORE GAS</b>				
UTILITY FUND 60	SEWER	NATURAL GAS SERVICE	GAS AT LIFT STATIONS & WELL HOUS	96.60
UTILITY FUND 60	SEWER	NATURAL GAS SERVICE	GAS AT LIFT STATIONS & WELL HOUS	47.75
UTILITY FUND 60	SEWER	NATURAL GAS SERVICE	GAS AT LIFT STATIONS & WELL HOUS	44.99
UTILITY FUND 60	SEWER	NATURAL GAS SERVICE	GAS AT LIFT STATIONS & WELL HOUS	45.64
UTILITY FUND 60	WATER	NATURAL GAS SERVICE	GAS AT LIFT STATIONS & WELL HOUS	109.90
UTILITY FUND 60	WATER	NATURAL GAS SERVICE	GAS AT LIFT STATIONS & WELL HOUS	172.28
UTILITY FUND 60	WATER	NATURAL GAS SERVICE	GAS AT LIFT STATIONS & WELL HOUS	93.82
UTILITY FUND 60	SEWER	NATURAL GAS SERVICE	GAS AT LIFT STATIONS & WELL HOUS	46.37
			<b>Vendor Total:</b>	<b>657.35</b>
<b>PACE ANALYTICAL SERVICES, LLC</b>				
UTILITY FUND 60	WATER	LAB SERVICE	LAB SERVICES	1,475.80 D
UTILITY FUND 60	SEWER	LAB SERVICE	JANUARY WWTF SAMPLING	1,195.40 D
			<b>Vendor Total:</b>	<b>2,671.20</b>
<b>PAYROLL - EXPENSES</b>				
I.M.R.F./F.I.C.A. 06	ADMINISTRATION	GENERAL ADMIN FICA	PAYROLL- EMPLOYER COSTS	3,164.75
REFUSE & RECYCLING 30		SOCIAL SECURITY CONTRIBUTION	PAYROLL- EMPLOYER COSTS	197.80
UTILITY FUND 60	SEWER & WATER ADMINISTRATION	SEWER/WATER FICA	PAYROLL- EMPLOYER COSTS	3,230.68
			<b>Vendor Total:</b>	<b>6,593.23</b>
<b>PAYROLL - GROSS PAYS</b>				
GENERAL FUND	ADMINISTRATION	ADMIN SALARIES	PAYROLL GROSS COMPENSATION	6,291.07
GENERAL FUND	ADMINISTRATION	SICK TIME COMPENSATION	PAYROLL GROSS COMPENSATION	2,187.59
GENERAL FUND	ENGINEERING & BUILDING	BLDG/ENG SALARIES	PAYROLL GROSS COMPENSATION	1,269.07
GENERAL FUND	ENGINEERING & BUILDING	SICK TIME COMPENSATION	PAYROLL GROSS COMPENSATION	274.28
GENERAL FUND	POLICE	SALARIES - ADMIN/RECORDS/CSO	PAYROLL GROSS COMPENSATION	2,060.00
GENERAL FUND	POLICE	SALARIES - OFFICERS	PAYROLL GROSS COMPENSATION	62,824.17
GENERAL FUND	POLICE	SALARIES - PART TIME OFFICERS	PAYROLL GROSS COMPENSATION	1,580.04
GENERAL FUND	POLICE	POLICE OVERTIME	PAYROLL GROSS COMPENSATION	850.54
GENERAL FUND	POLICE	SICK TIME COMPENSATION	PAYROLL GROSS COMPENSATION	22,764.19
GENERAL FUND	PUBLIC WORKS	PUBLIC WORKS SALARIES	PAYROLL GROSS COMPENSATION	13,574.54
GENERAL FUND	PUBLIC WORKS	PUBLIC WORKS OVER-TIME	PAYROLL GROSS COMPENSATION	611.58
GENERAL FUND	PUBLIC WORKS	ON-CALL/CALL OUT PAY	PAYROLL GROSS COMPENSATION	1,020.18
GENERAL FUND	PUBLIC WORKS	PART TIME WINTER PERSONNEL	PAYROLL GROSS COMPENSATION	1,824.00
GENERAL FUND	PUBLIC WORKS	SICK TIME COMPENSATION	PAYROLL GROSS COMPENSATION	2,162.33
REFUSE & RECYCLING 30		SALARIES	PAYROLL GROSS COMPENSATION	2,605.70
REFUSE & RECYCLING 30		SICK TIME COMPENSATION	PAYROLL GROSS COMPENSATION	492.37

Fund		Department	BOTH OPEN AND PAID Line Item	Item Description	Amount
UTILITY FUND	60	SEWER & WATER ADMINISTRATION	S/W OFFICE SALARIES	PAYROLL GROSS COMPENSATION	6,777.22
UTILITY FUND	60	SEWER & WATER ADMINISTRATION	SICK TIME COMPENSATION	PAYROLL GROSS COMPENSATION	1,969.50
UTILITY FUND	60	SEWER	SEWER SALARIES	PAYROLL GROSS COMPENSATION	13,574.54
UTILITY FUND	60	SEWER	SEWER OVER-TIME	PAYROLL GROSS COMPENSATION	611.58
UTILITY FUND	60	SEWER	ON-CALL/CALL-OUT PAY	PAYROLL GROSS COMPENSATION	1,020.18
UTILITY FUND	60	SEWER	SICK TIME COMPENSATION	PAYROLL GROSS COMPENSATION	2,162.33
UTILITY FUND	60	WATER	WATER SALARIES	PAYROLL GROSS COMPENSATION	6,787.27
UTILITY FUND	60	WATER	OVERTIME	PAYROLL GROSS COMPENSATION	305.79
UTILITY FUND	60	WATER	ON-CALL/CALL-OUT PAY	PAYROLL GROSS COMPENSATION	510.09
UTILITY FUND	60	WATER	SICK TIME COMPENSATION	PAYROLL GROSS COMPENSATION	1,081.16
				<b>Vendor Total:</b>	<b>157,191.31</b>
<b>PAYROLL - PROCESSING FEES</b>					
GENERAL FUND		ADMINISTRATION	CONTRACT PAYROLL SERVICES	PAYROLL - PAYLOCITY FEES	207.64
REFUSE & RECYCLING	30		GARBAGE CONTRACTUAL SERVICES	PAYROLL - PAYLOCITY FEES	46.15
UTILITY FUND	60	SEWER & WATER ADMINISTRATION	CONTRACT PAYROLL SERVICES	PAYROLL - PAYLOCITY FEES	207.64
				<b>Vendor Total:</b>	<b>461.43</b>
<b>PORTER LEE CORPORATION</b>					
GENERAL FUND		POLICE	MISC CONTRACTUAL SERVICES	ANNUAL BEAST SOFTWARE - PD	920.00
				<b>Vendor Total:</b>	<b>920.00</b>
<b>PRECISE MRM LLC</b>					
GENERAL FUND		PUBLIC WORKS	VEHICLE & EQUIPMENT SUPPLIES	GPS DATA PLAN	96.00
UTILITY FUND	60	SEWER & WATER ADMINISTRATION	VEHICLE & EQUIPMENT SUPPLIES	GPS DATA PLAN	64.00
				<b>Vendor Total:</b>	<b>160.00</b>
<b>RUSH ADMINISTRATIVE SERVICES</b>					
GENERAL FUND		PUBLIC WORKS	SNOW PLOW PARTS AND SUPPLIES	TRUCK MIRRORS	32.28
UTILITY FUND	60	SEWER & WATER ADMINISTRATION	EQUIPMENT MAINTENANCE - OFFICE	TRUCK MIRRORS	21.52
				<b>Vendor Total:</b>	<b>53.80</b>
<b>RUSH POWER SYSTEMS, LLC</b>					
UTILITY FUND	60	SEWER	EQUIPMENT REPAIRS & MAINTENANCE	LS 10 ATS INSPECTION	392.06 D
UTILITY FUND	60	SEWER	EQUIPMENT REPAIRS & MAINTENANCE	LS 5 GEN BLOCK HEATER REPAIR	884.13 D
GENERAL FUND		BUILDING & GROUNDS	REPAIRS & MAINTENANCE	PD GEN BLOCK HEATER REPAIR	562.15 D
				<b>Vendor Total:</b>	<b>1,838.34</b>
<b>SAFEBUILT LLC LOCKBOX 88135</b>					
GENERAL FUND		POLICE	SALARIES-P/T CSO/FRONT DESK	CODE ENFORCEMENT - JANUARY	920.00
				<b>Vendor Total:</b>	<b>920.00</b>
<b>SONDAY SERVICES</b>					
UTILITY FUND	60	WATER	DISTRIBUTION SYSTEM REPAIRS	2408 ROSE TREE LANE - WATER MAIN	8,138.00 D
UTILITY FUND	60	WATER	DISTRIBUTION SYSTEM REPAIRS	1916 BURR OAK LN - WATER MAIN RE	6,573.00 D
UTILITY FUND	60	WATER	DISTRIBUTION SYSTEM REPAIRS	1903 HAZELWOOD DR - WATER MAIN F	6,880.00 D
				<b>Vendor Total:</b>	<b>21,591.00</b>
<b>SWALCO</b>					
REFUSE & RECYCLING	30		RECYCLE PROGRAM - SWALCO	SWALCO 2025 - OPERATION & MAINTENANCE	6,483.75
				<b>Vendor Total:</b>	<b>6,483.75</b>
<b>SWANSON, MARTIN &amp; BELL, LLP</b>					
GENERAL FUND		POLICE	LEGAL EXPENSE	DECEMBER 2024 PROSECUTION MATTER	3,404.00 D
				<b>Vendor Total:</b>	<b>3,404.00</b>
<b>ULINE</b>					
GENERAL FUND		PUBLIC WORKS	TOOLS	DRUM PUMP	349.50
UTILITY FUND	60	SEWER & WATER ADMINISTRATION	TOOLS	DRUM PUMP	349.50
				<b>Vendor Total:</b>	<b>699.00</b>
<b>USA BLUEBOOK</b>					
UTILITY FUND	60	SEWER & WATER ADMINISTRATION	OPERATING SUPPLIES	REDI 8 UNIT	1,839.95
UTILITY FUND	60	SEWER & WATER ADMINISTRATION	OPERATING SUPPLIES	CREDIT MEMO # 800190	(53.96)
				<b>Vendor Total:</b>	<b>1,785.99</b>
<b>USIC LOCATING SERVICES, INC</b>					
UTILITY FUND	60	SEWER & WATER ADMINISTRATION	JULIE - CONTRACT UTILITY LOCATING SERVICES	JANUARY 2025 LOCATING SERVICES	1,628.44 D
				<b>Vendor Total:</b>	<b>1,628.44</b>
<b>VERIZON WIRELESS</b>					
GENERAL FUND		POLICE	TELEPHONE	PD CELL PHONES	169.40
UTILITY FUND	60	SEWER & WATER ADMINISTRATION	TELEPHONE	PW INTERNET, CELL PHONES & TABLE	446.24

VILLAGE OF LINDENHURST Treasurer's Report  
 EXP CHECK RUN DATES 01/28/2025 - 02/10/2025  
 BOTH JOURNALIZED AND UNJOURNALIZED

Fund	Department	Line Item	Item Description	Amount
<b>Vendor Total:</b>				<b>615.64</b>
<b>WEX BANK</b>				
GENERAL FUND	POLICE	GAS & OIL	PD FUEL	3,345.44
GENERAL FUND	PUBLIC WORKS	FUEL & OIL	PW FUEL	714.06
UTILITY FUND 60	SEWER & WATER ADMINISTRATION	GAS & OIL	PW FUEL	1,666.13
<b>Vendor Total:</b>				<b>5,725.63</b>
<b>Grand Total:</b>				<b>1,092,067.20</b>

**Fund Totals:**

GENERAL FUND 01	196,911.49
I.M.R.F./F.I.C.A. FUND 06	12,200.50
IT FUND 11	8,798.30
COMMUNITY CAPITAL FUND 21	13,143.50
MISCELLANEOUS ESCROW FUND 24	2,219.75
SHOP WITH A COP FUND 25	300.00
REFUSE & RECYCLING FUND 30	121,680.02
UTILITY FUND 60	736,756.24
SANITARY DISTRICT FUND 89	57.40
<b>Total For All Funds:</b>	<b>\$1,092,067.20</b>



# Village of Lindenhurst Strategic Priority Dashboard

Welcome to the Village of Lindenhurst's Strategic Priority Dashboard! This interactive tool provides key performance indicators (KPIs) selected by each Village department and functional area to track progress towards our Strategic Plan and operational goals.

## *Mission Statement*

The Village of Lindenhurst, in partnership with our community, continuously strives to provide a safe, healthy, and vibrant environment through quality customer service, public safety, progressive leadership, and financial responsibility.

## Village Functional Areas

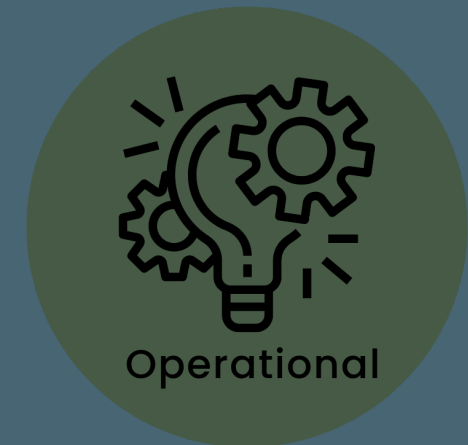
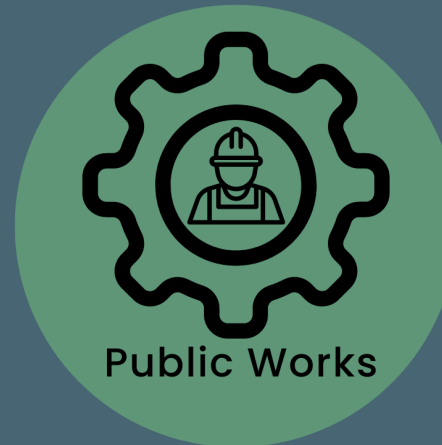

All data is displayed by Fiscal Year (FY), unless otherwise specified. The Village's fiscal year runs from May 1- April 30.



# Administration & Communications

## Village Strategic Plan Alignment Key

- Community Branding & Engagement
- Responsible Growth & Development
- Future Ready Operations
- Capital Infrastructure Planning & Improvements
- Business Recruitment & Retention
- Operational/Unaffiliated

### Service Requests Completion

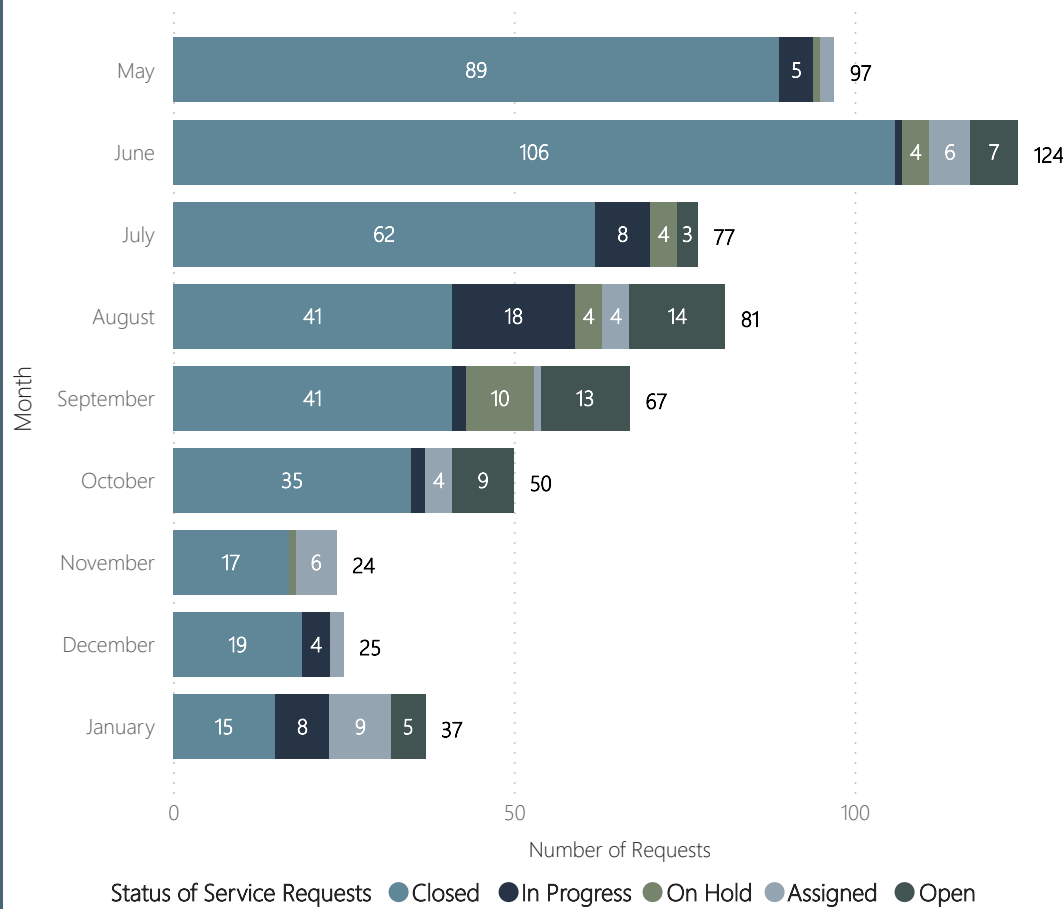

### Social Media Total Engagement

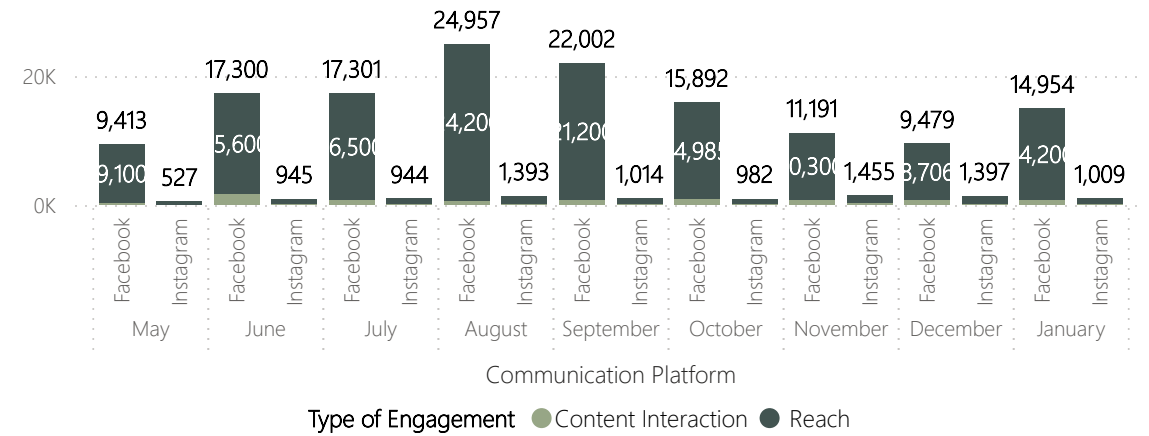

### Village Social Media Platform Followers

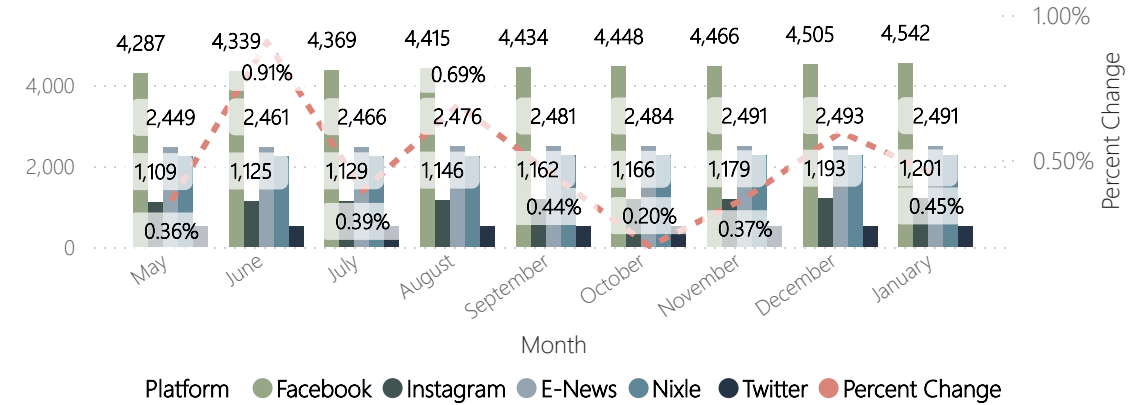

### Website Views

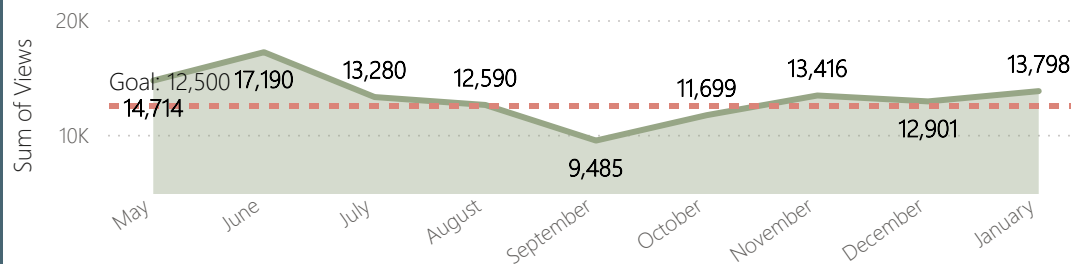

### E-Newsletter Open Rate

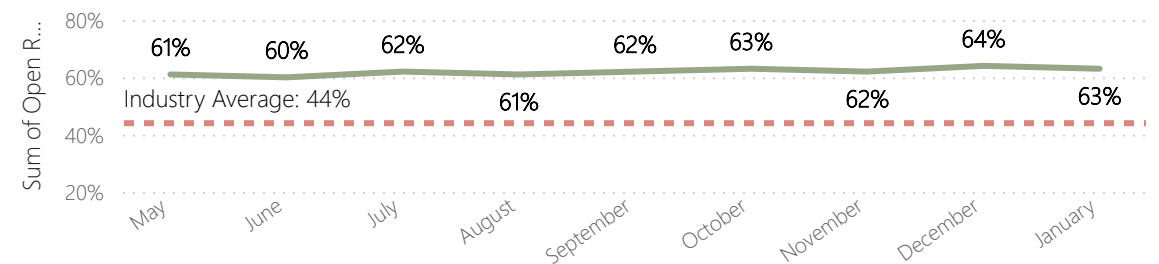



### Village Strategic Plan Alignment Key

- Community Branding & Engagement
- Responsible Growth & Development
- Future Ready Operations
- Capital Infrastructure Planning & Improvements
- Business Recruitment & Retention
- Operational/ Unaffiliated

## Finance

### General Fund Cash Balance ●

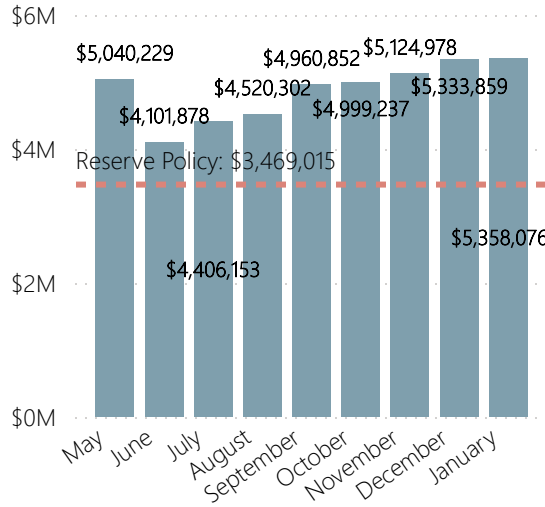

### MFT Fund Cash Balance ●

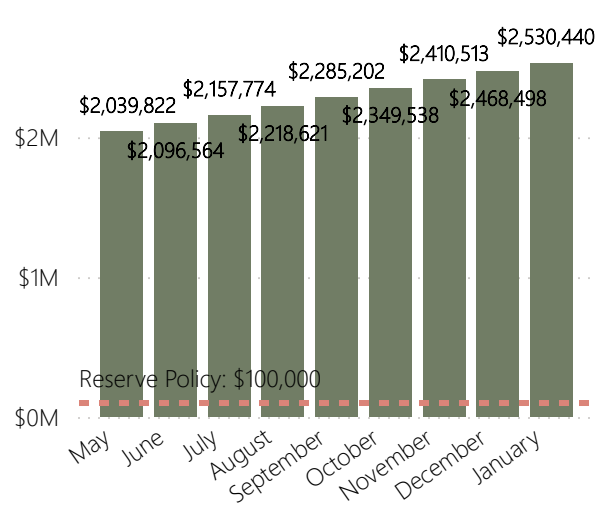

### Water/ Sewer Fund Cash Balance ● Garbage Fund Cash Balance ●

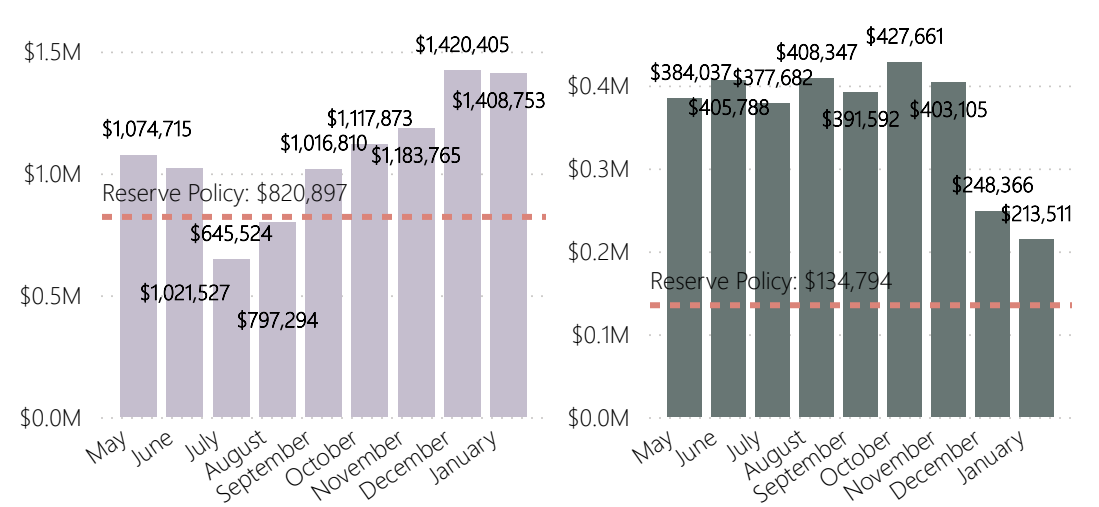

### Annual Village Property Tax Rate ●

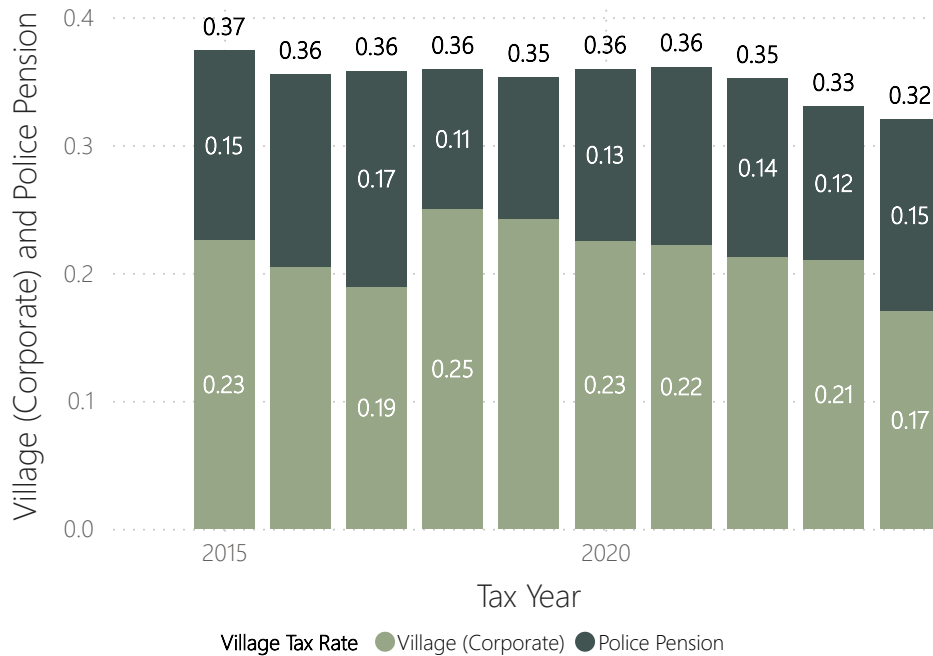

### Property Tax Rate by Taxing Body ●

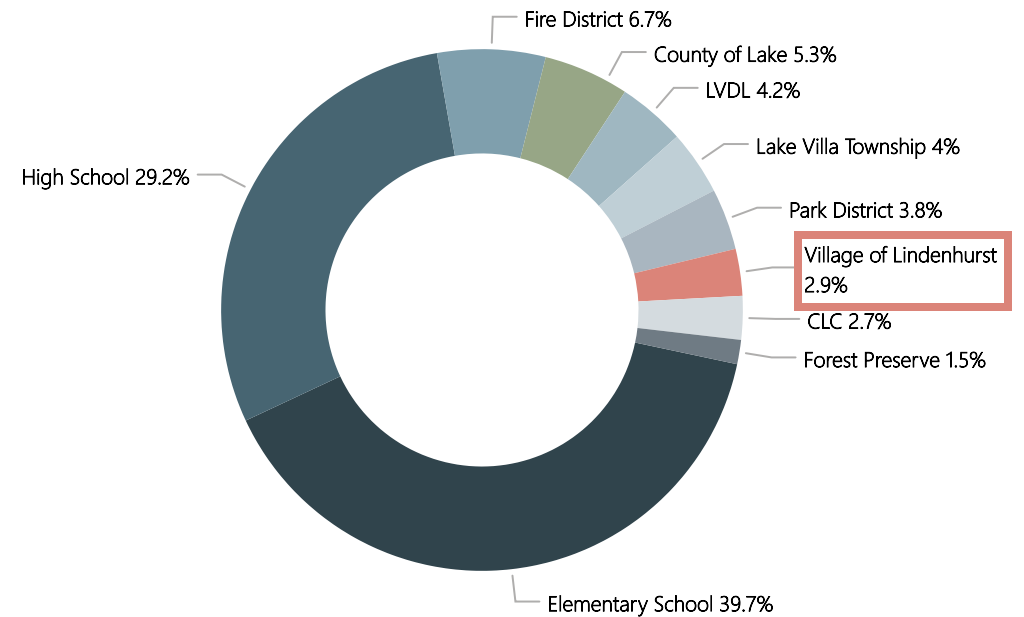



### Village Strategic Plan Alignment Key

- Community Branding & Engagement
- Responsible Growth & Development
- Future Ready Operations
- Capital Infrastructure Planning & Improvements
- Business Recruitment & Retention
- Operational/Unaffiliated

## Development

### LEAP Dollars Awarded to Businesses

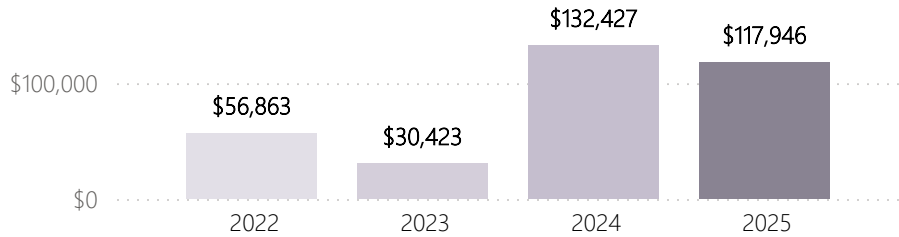

### Monthly Building Permit Information

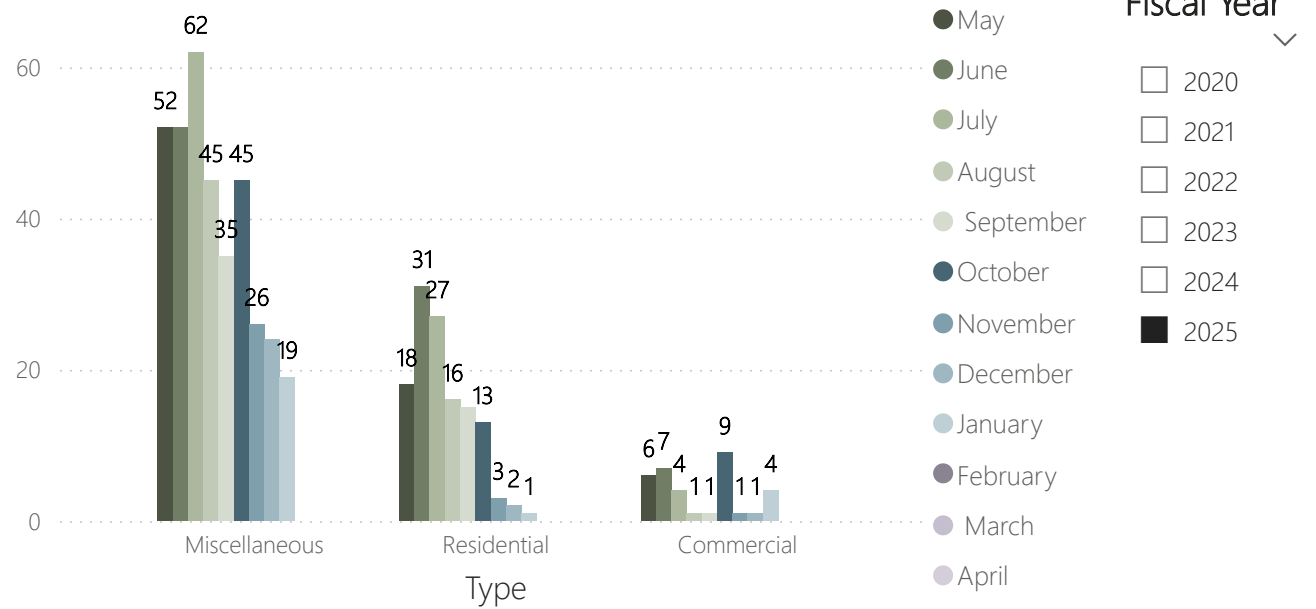

### Sales Tax

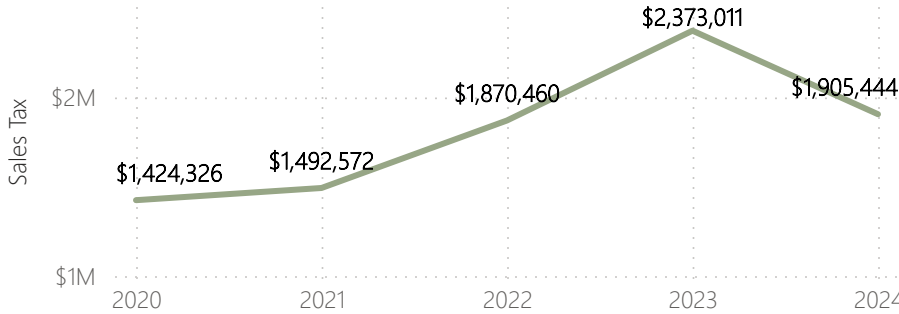

### Lindenhurst Taxable Equalized Assesed Value (EAV)

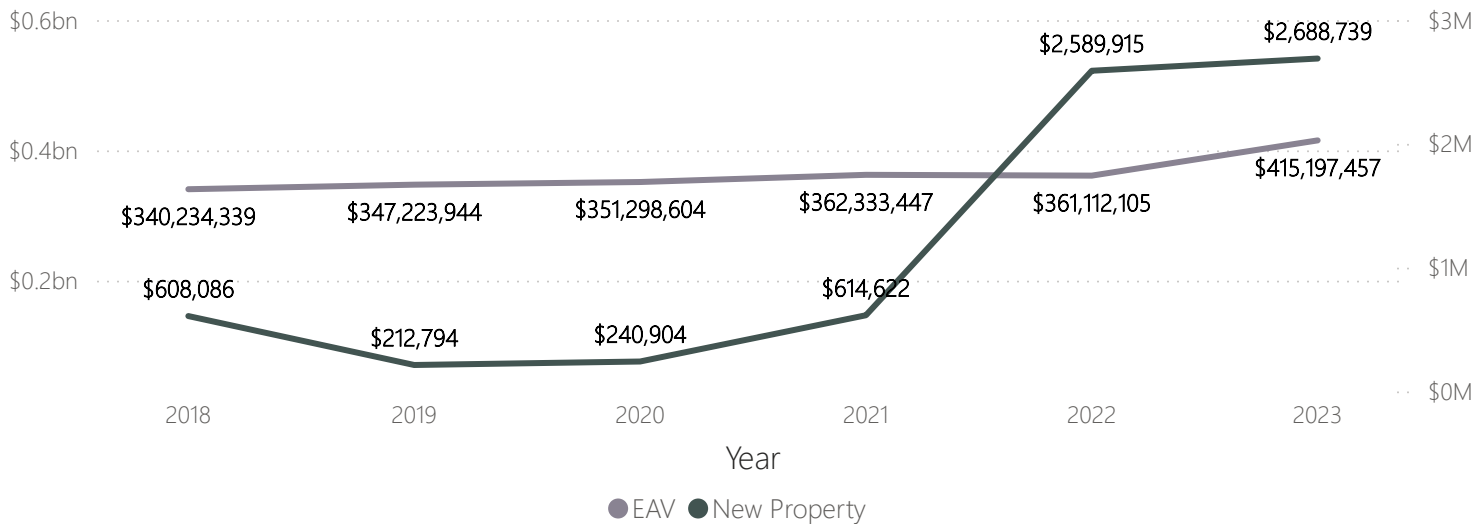

### Fiscal Year Business License Information

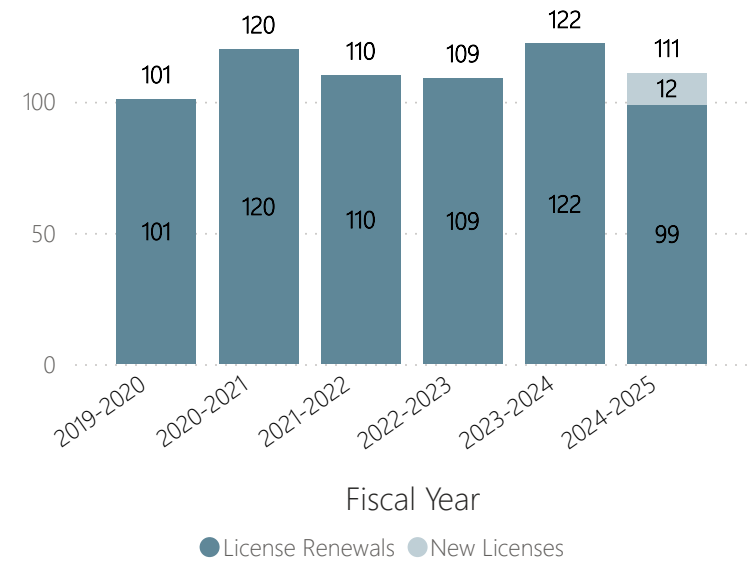



### Village Strategic Plan Alignment Key

- Community Branding & Engagement
- Responsible Growth & Development
- Future Ready Operations
- Capital Infrastructure Planning & Improvements
- Business Recruitment & Retention
- Operational/Unaffiliated

# Public Works

### January-Time Spent in Functional Areas

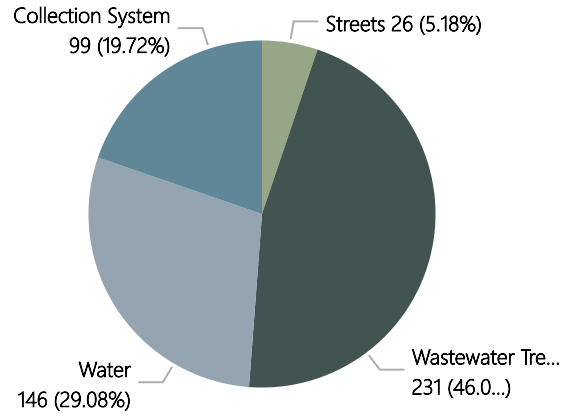

### Time Performed in Public Works Functional Area

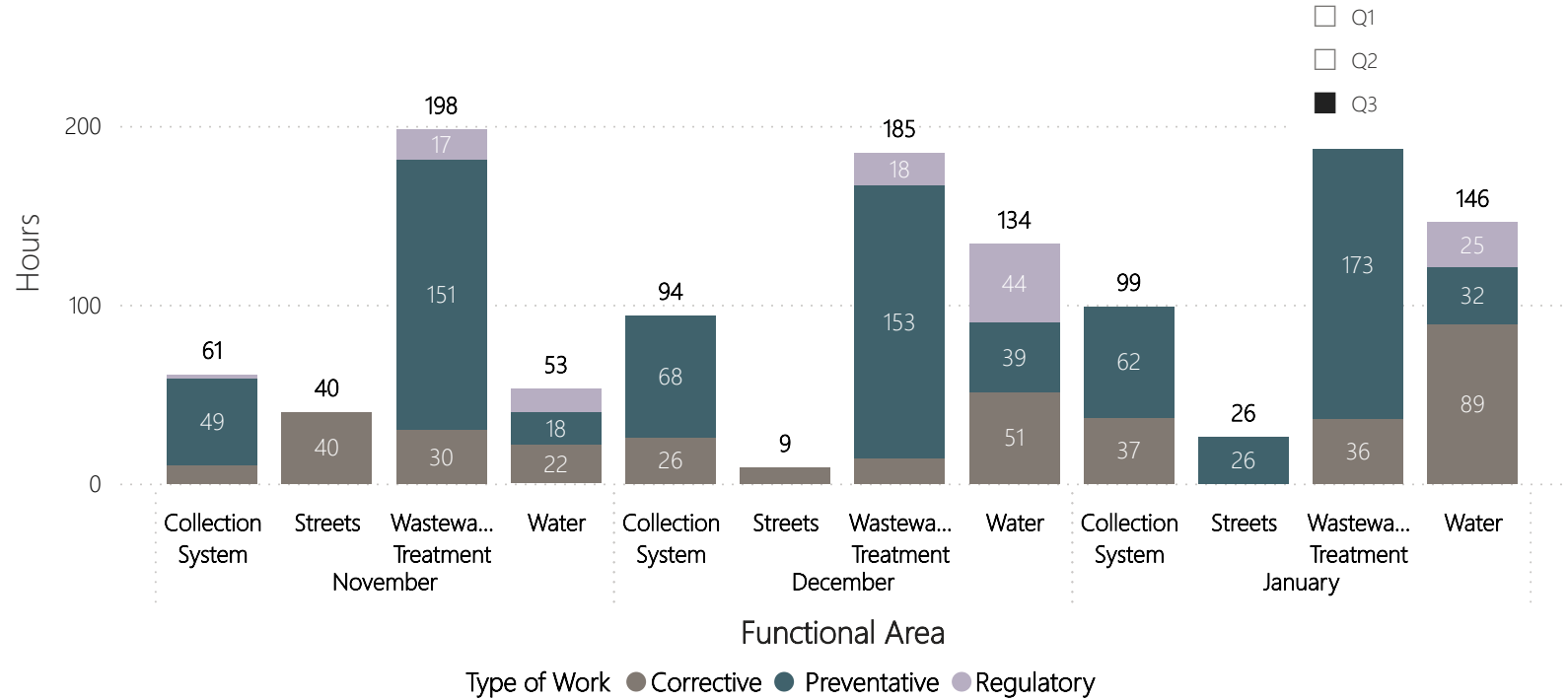

### 2024-2025 Snow Season- Hours to Complete Event

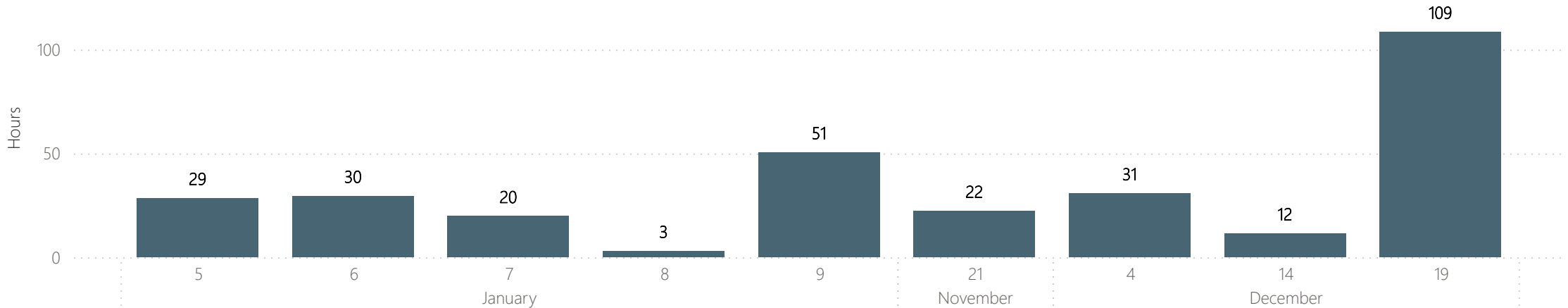



# Public Works

## Village Strategic Plan Alignment Key

- Community Branding & Engagement
- Responsible Growth & Development
- Future Ready Operations
- Capital Infrastructure Planning & Improvements
- Business Recruitment & Retention
- Operational/ Unaffiliated

### After Hour Call Outs: Water

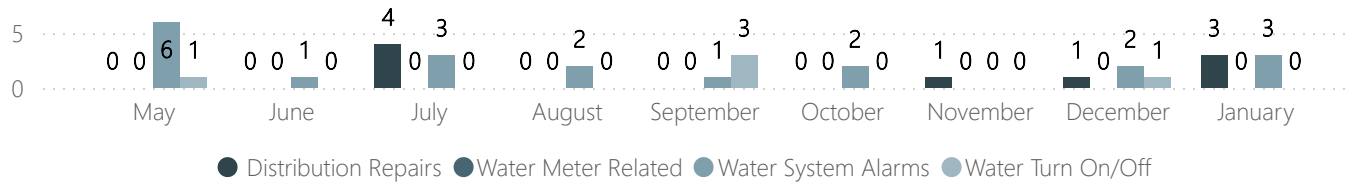

### After Hour Call Outs: Sanitary

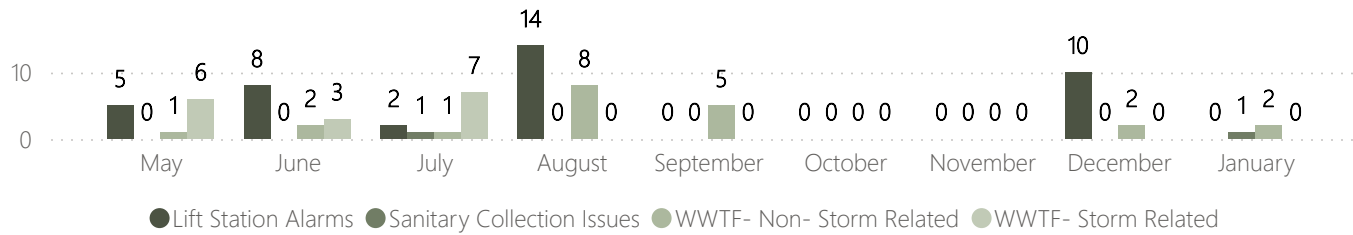

### After Hour Call Outs: Streets

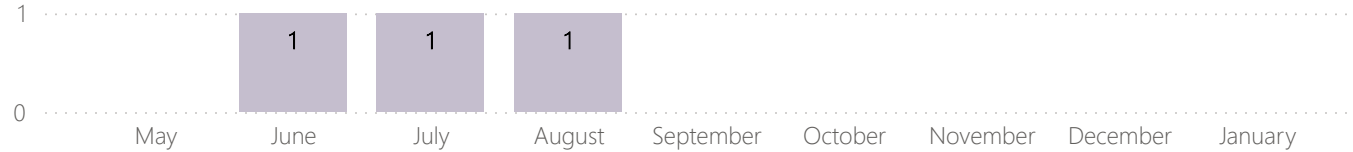

### Distribution Repairs

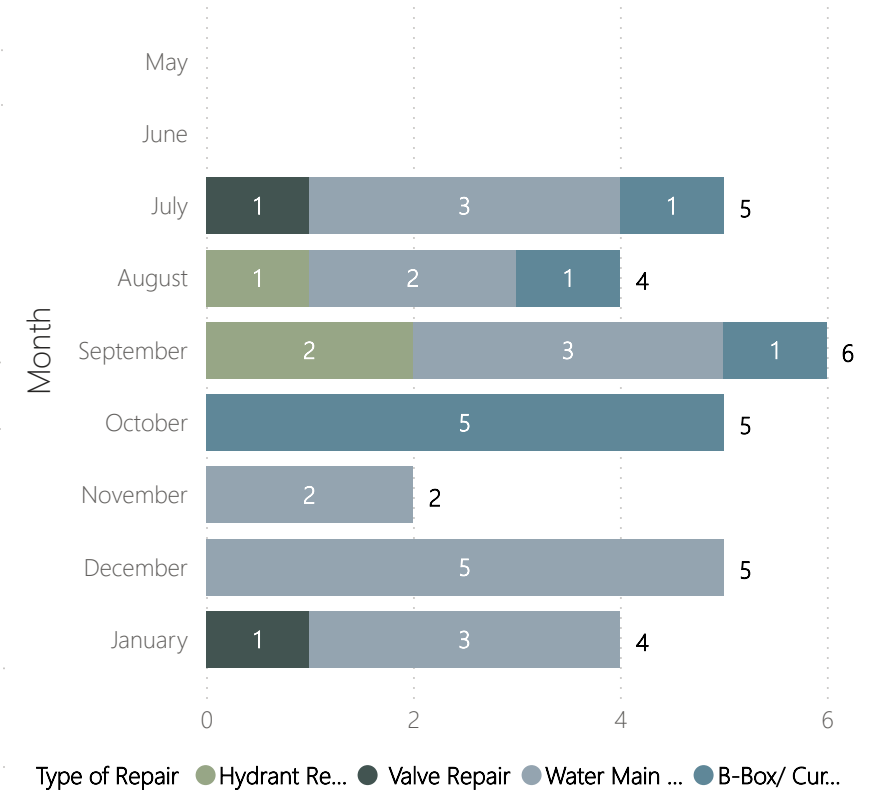

### Daily Flow Levels with Daily Precipitation

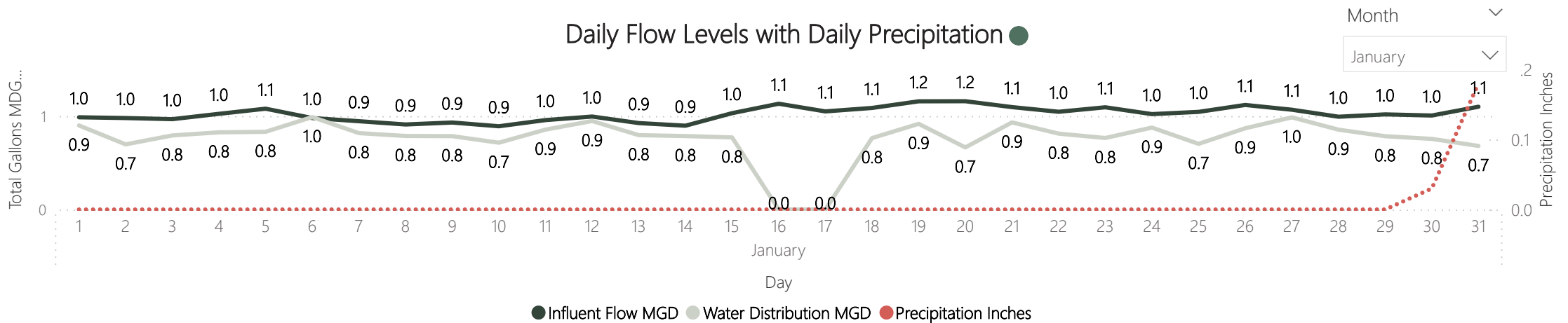



### Village Strategic Plan Alignment Key

- Community Branding & Engagement
- Responsible Growth & Development
- Future Ready Operations
- Capital Infrastructure Planning & Improvements
- Business Recruitment & Retention
- Operational/Unaffiliated

# Police

### Calls for Service

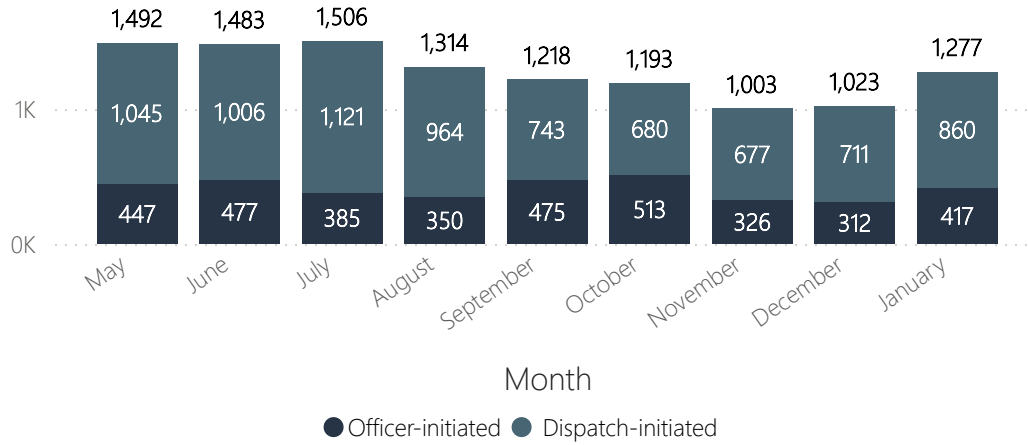

### Arrest Data

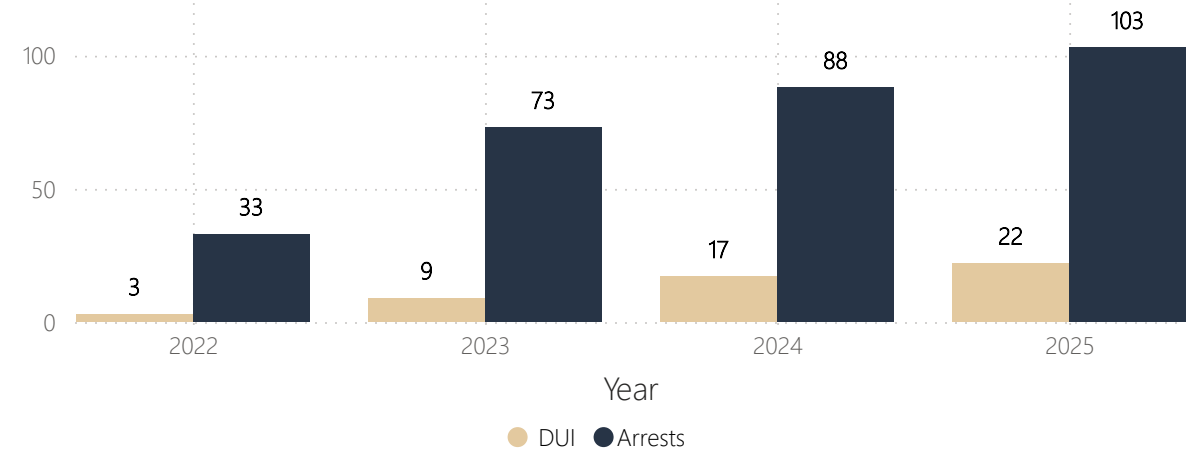

### Traffic Enforcement

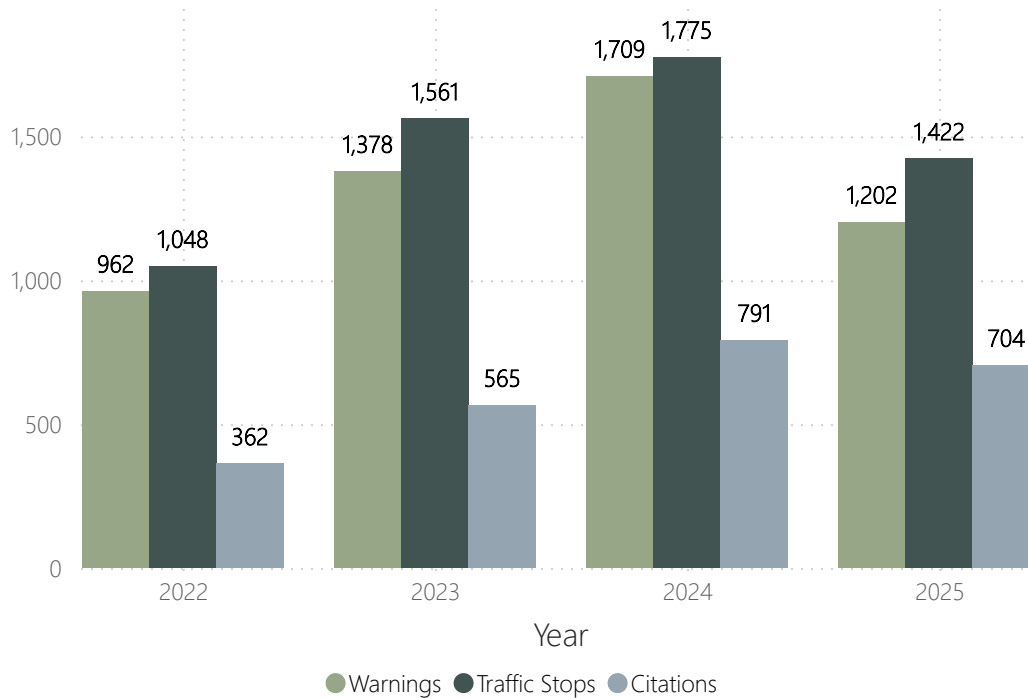

### Accident Data

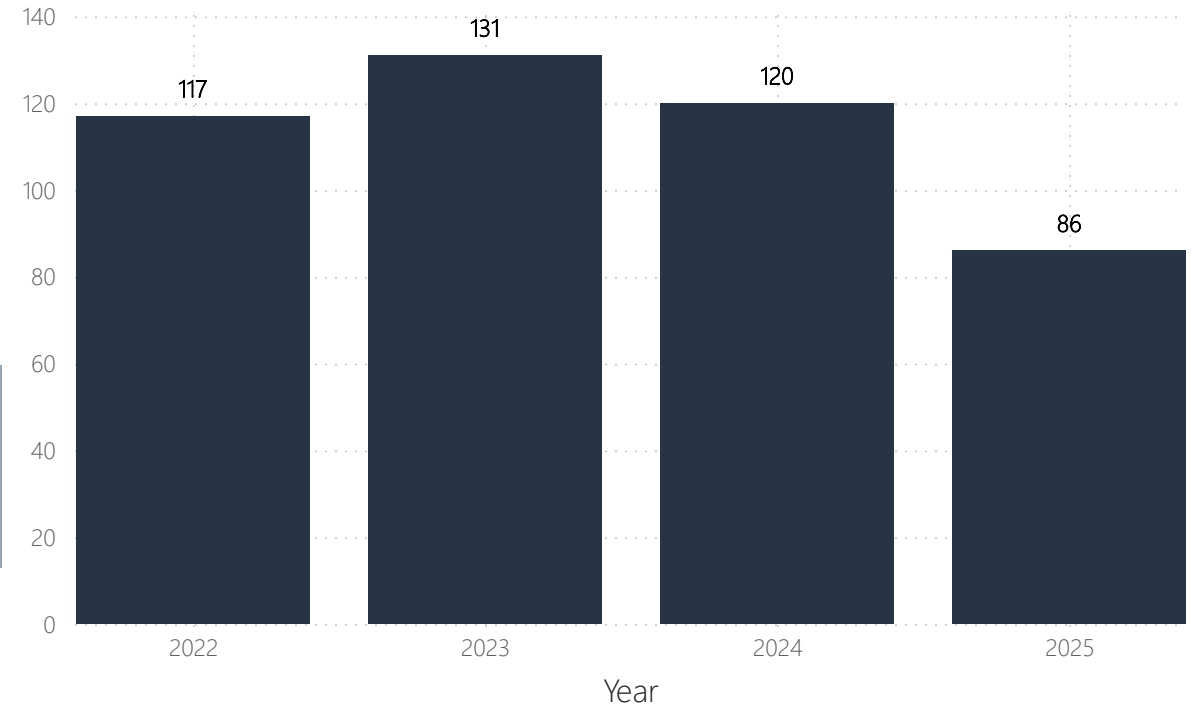



# Capital Projects Tracking

Filter by Capital Project Category

- General Government Improvements
- Green/Sustainability Improvements
- Street Improvements
- Village Facilities & Equipment
- Water & Wastewater

Capital Projects Progress by Category

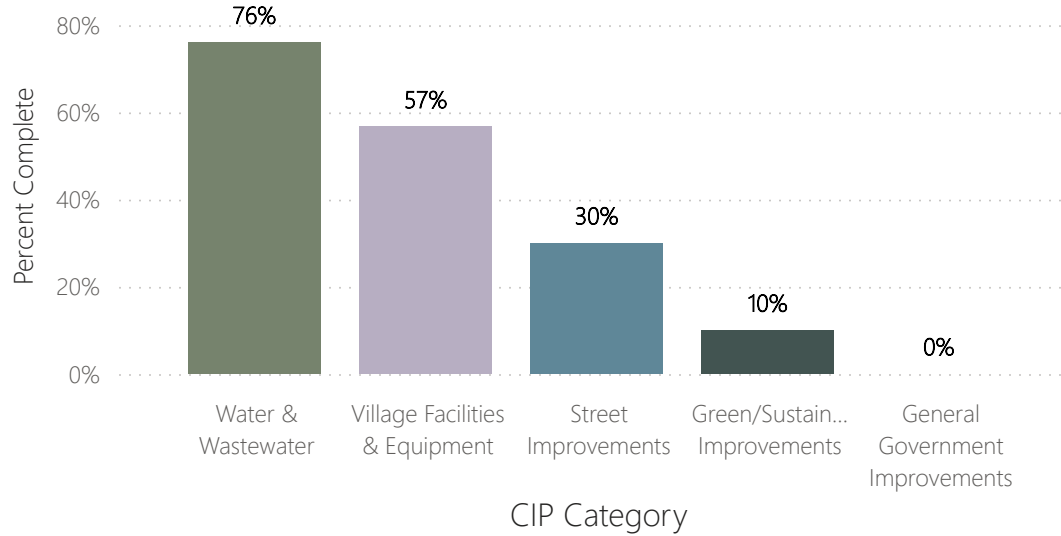

Capital Projects Progress by Project

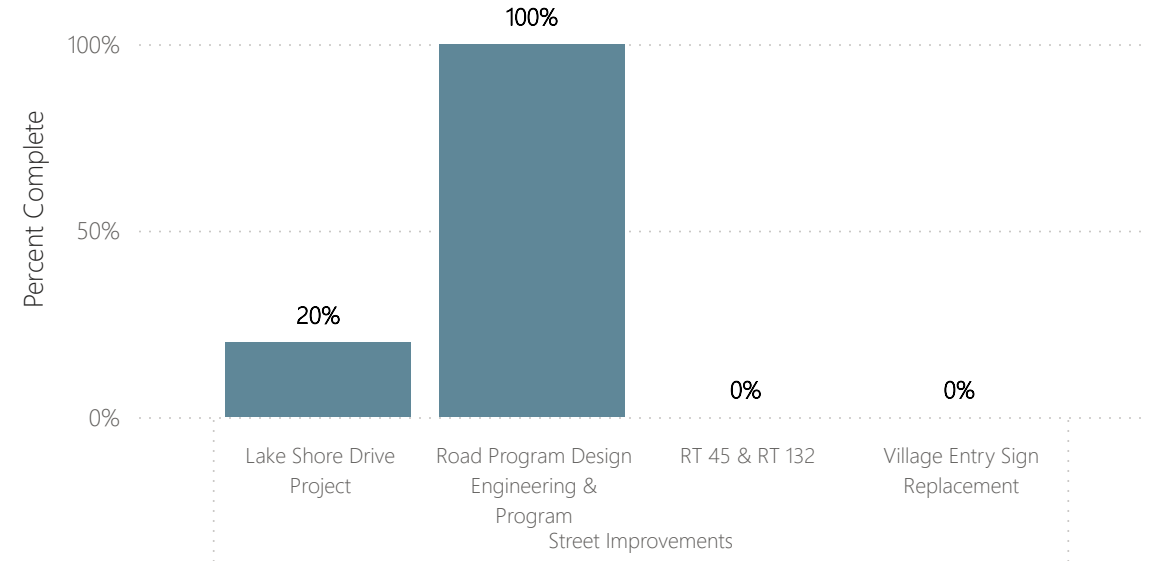

## Village Strategic Plan Alignment Key

- Community Branding & Engagement
- Responsible Growth & Development
- Future Ready Operations
- Capital Infrastructure Planning & Improvements
- Business Recruitment & Retention
- Operational/Unaffiliated

CIP Category	% Complete	Project Description
<ul style="list-style-type: none"> <li>☐ Street Improvements                             <ul style="list-style-type: none"> <li>☐ Lake Shore Drive Reconstruction &amp; Engineering</li> <li>☐ Misc. Street Improvements</li> <li>☐ Road Resurfacing Program</li> <li>☐ Village Match for County/State Road Projects</li> </ul> </li> </ul>	<ul style="list-style-type: none"> <li>20%</li> <li>0%</li> <li>100%</li> <li>0%</li> </ul>	<ul style="list-style-type: none"> <li>Com ED relocated their utility poles. AT&amp;T is in the process of moving utilities. Northbound lane of Lake Shore Drive has been shut down. Contractor is working on storm system installation.No change in status</li> <li>Project is awaiting results from Grand Avenue Streetscaping project to align with the design concept.</li> <li>2024 MFT road resurfacing program was completed.</li> <li>Village's contribution for County &amp; State Road Project</li> </ul>

# Village of Lindenhurst Financial Tracking and Detail Report



## Annual General Fund Revenues by Type

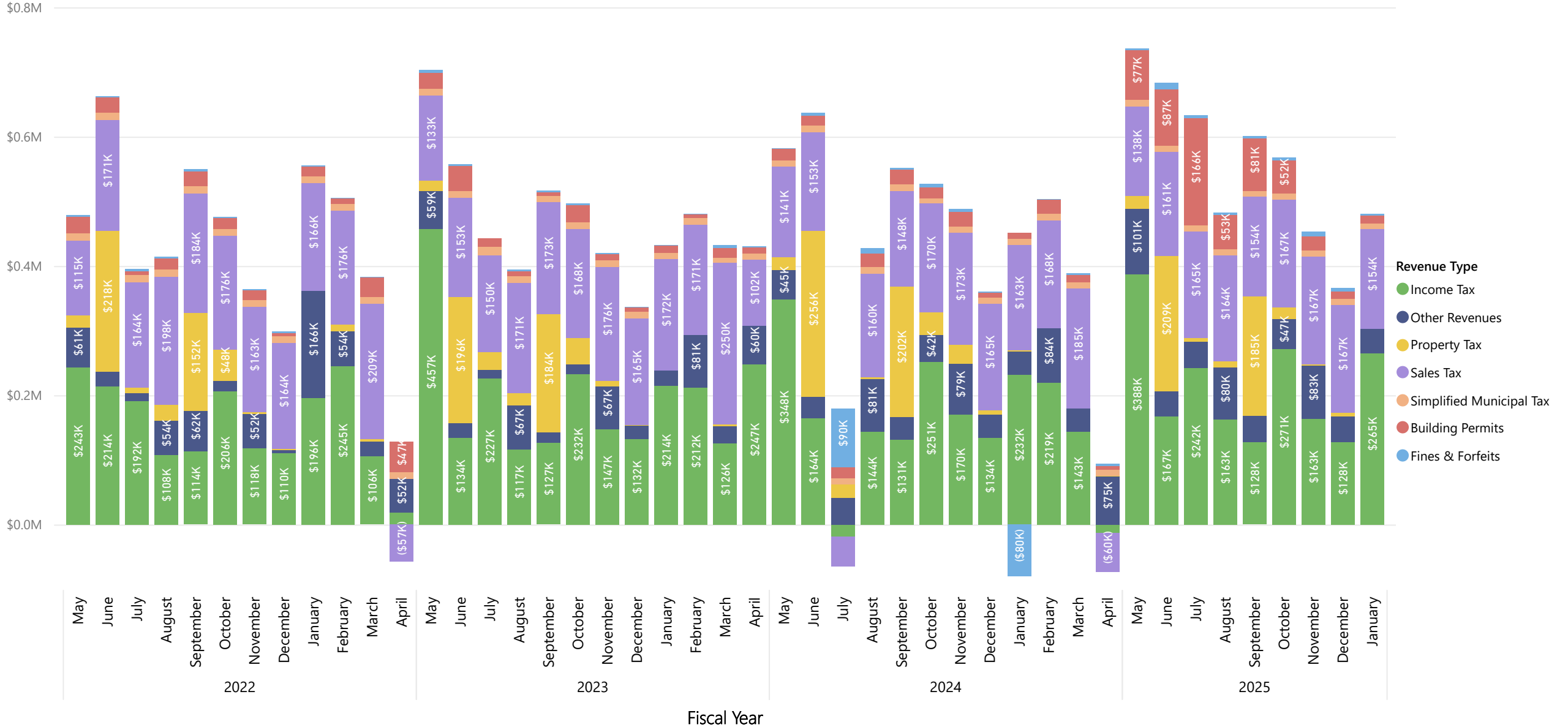

# Village of Lindenhurst Financial Tracking and Detail Report



## Annual Water and Sewer Receipts

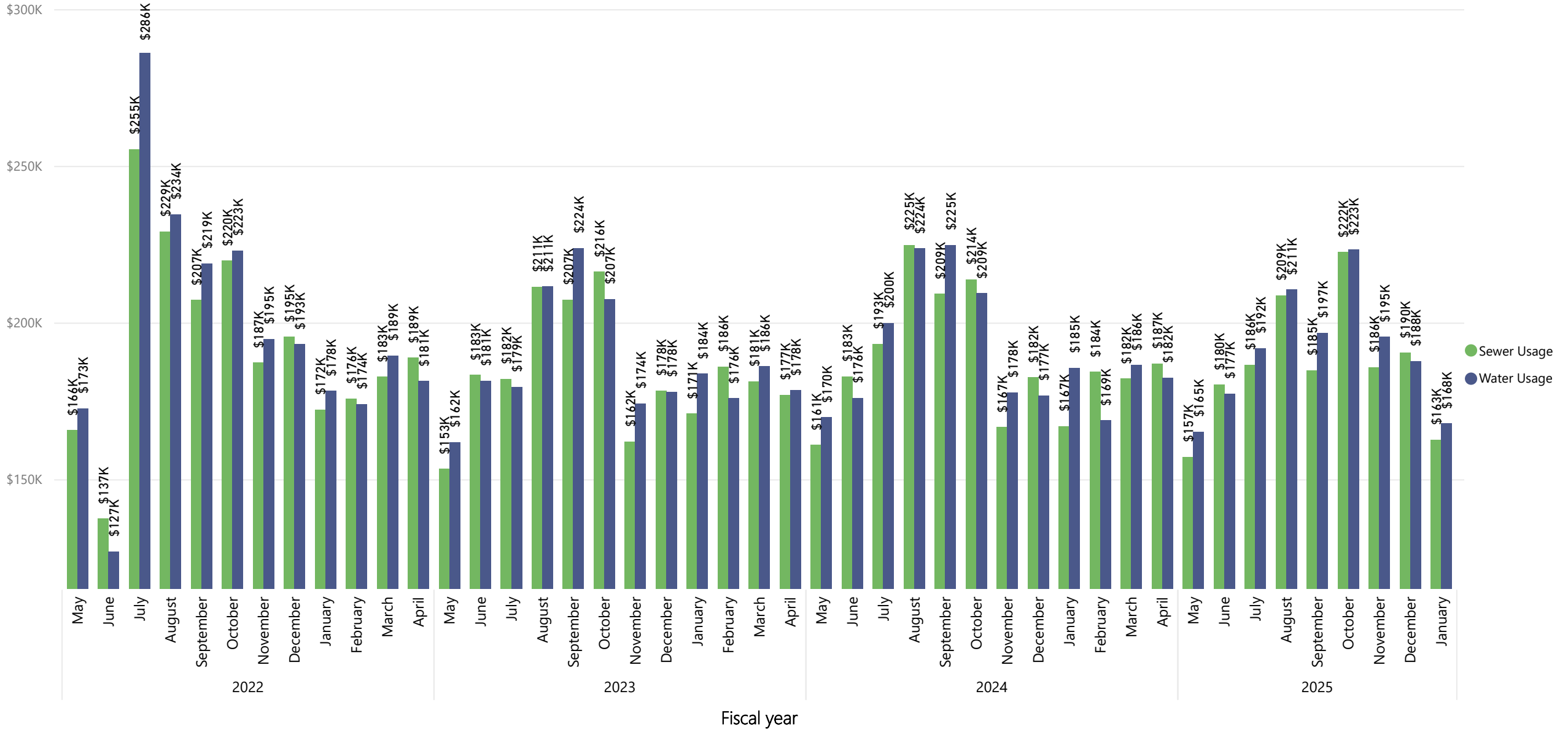

General Fund  
Individual  
Revenue  
Sources

Property Tax Receipts by Month

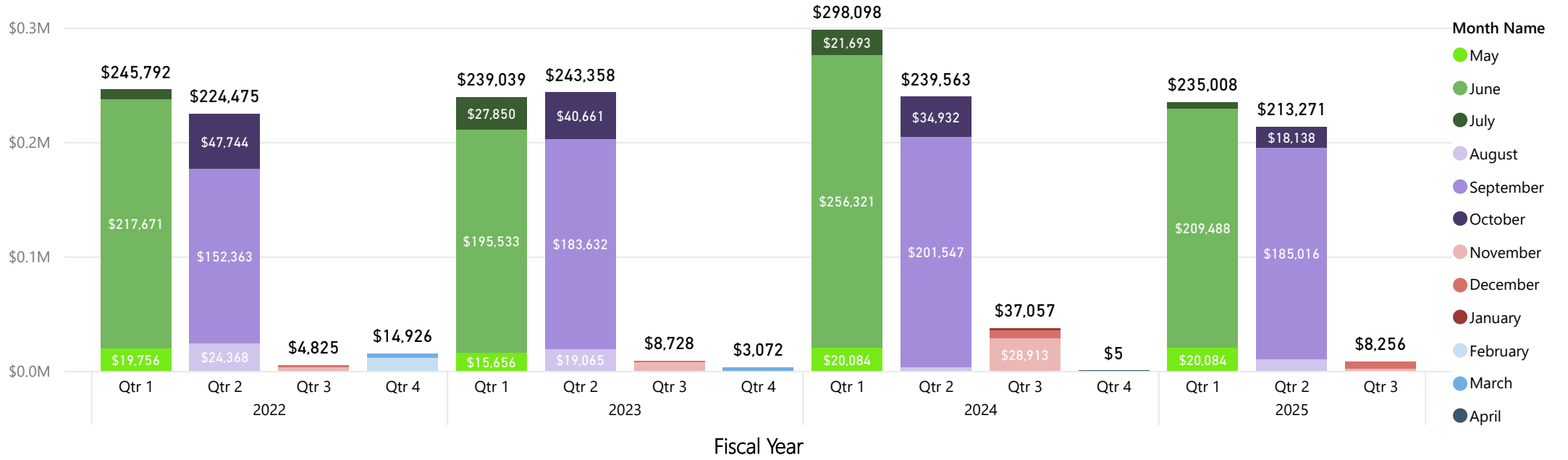

Income Tax Receipts by Month

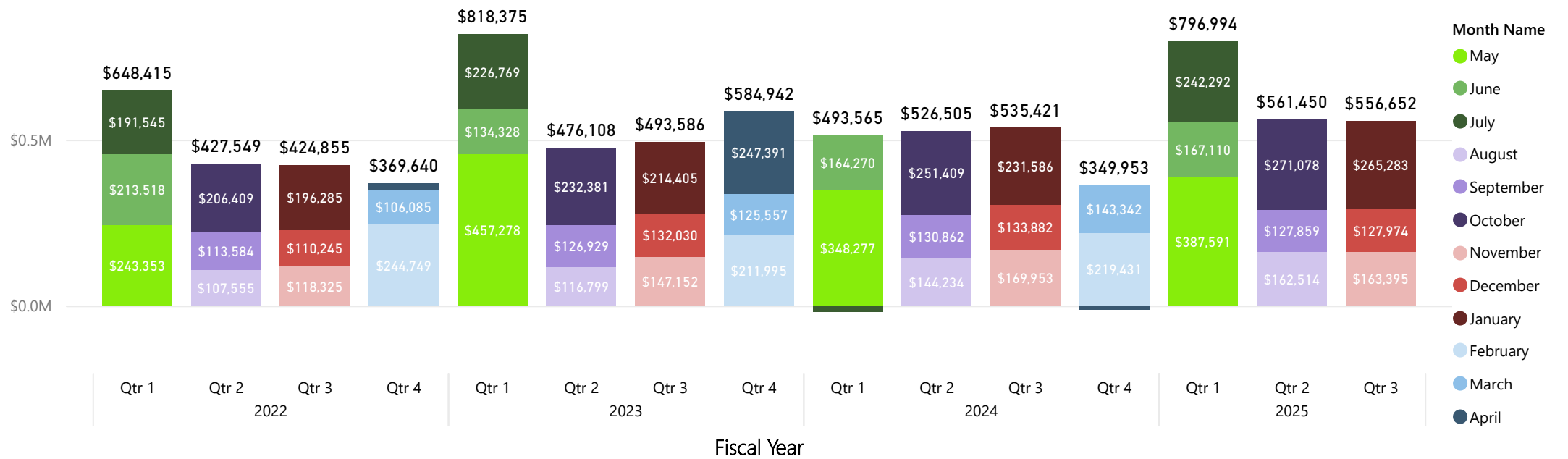

General Fund  
Individual Revenue Sources

Building Permits Receipts by Month

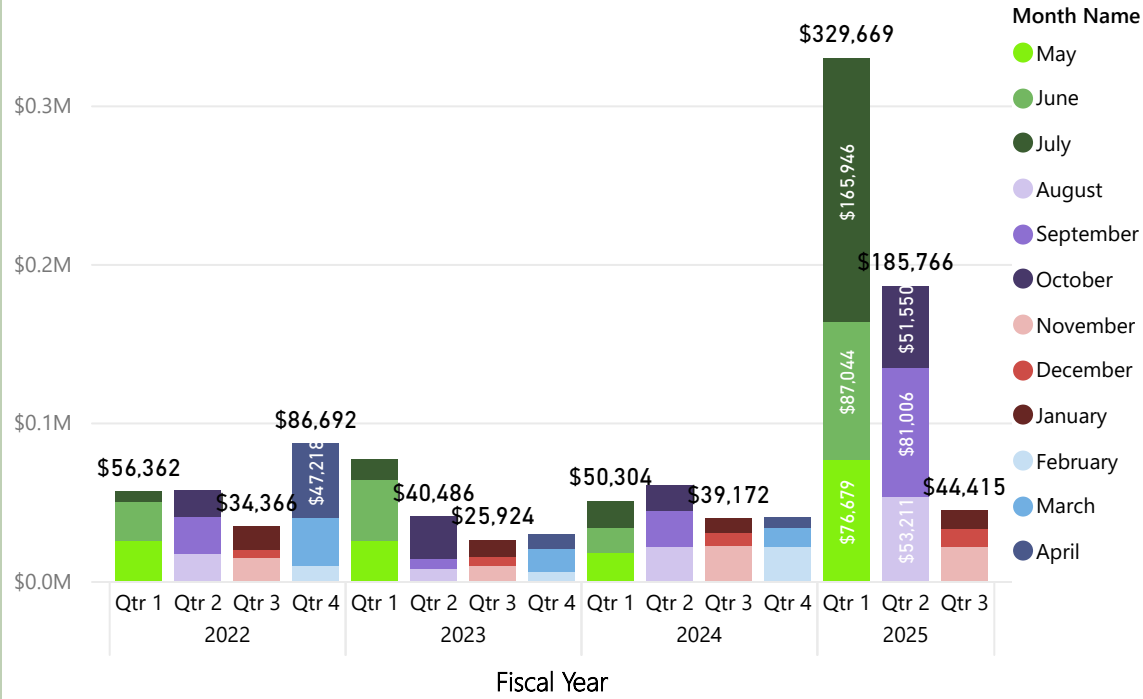

Simplified Municipal Tax Receipts by Month

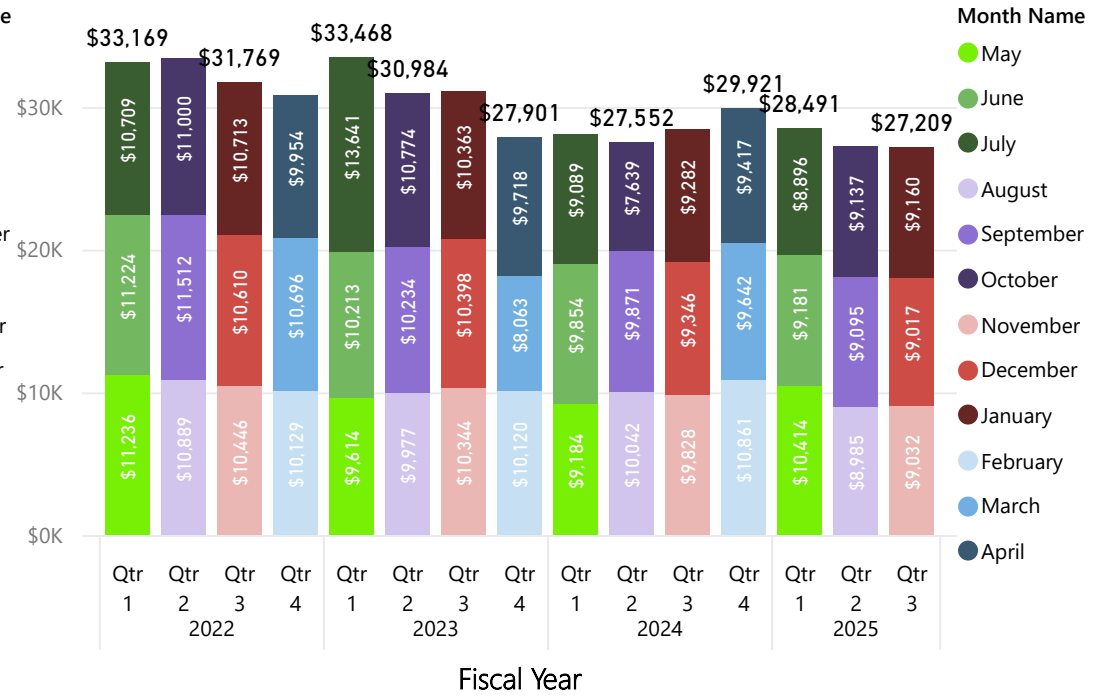

Sales Tax Receipts by Month

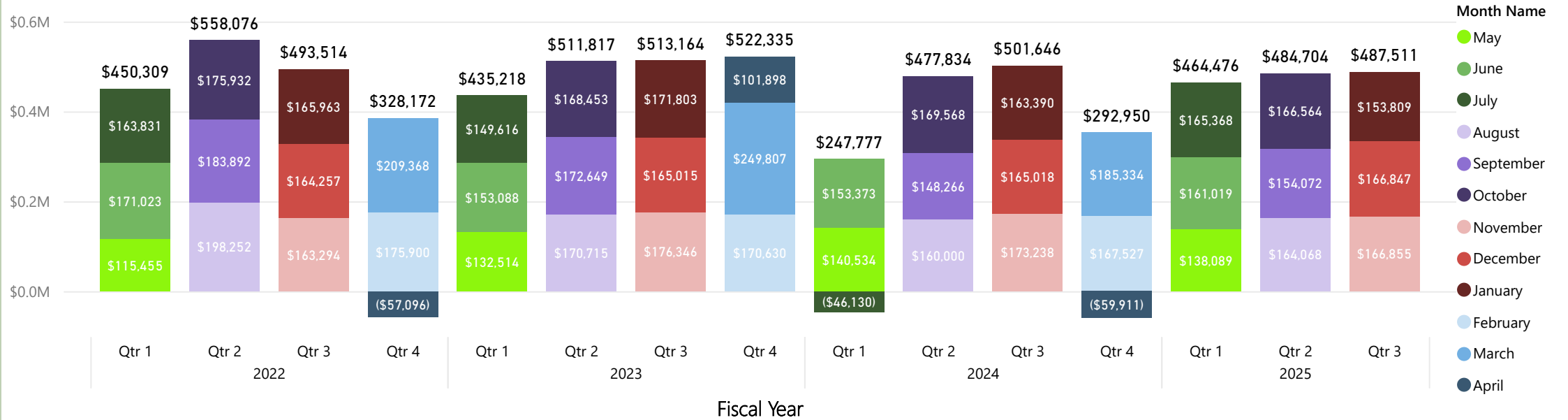

# Water/ Sewer Revenues by Month

## Water Usage Revenues by Month

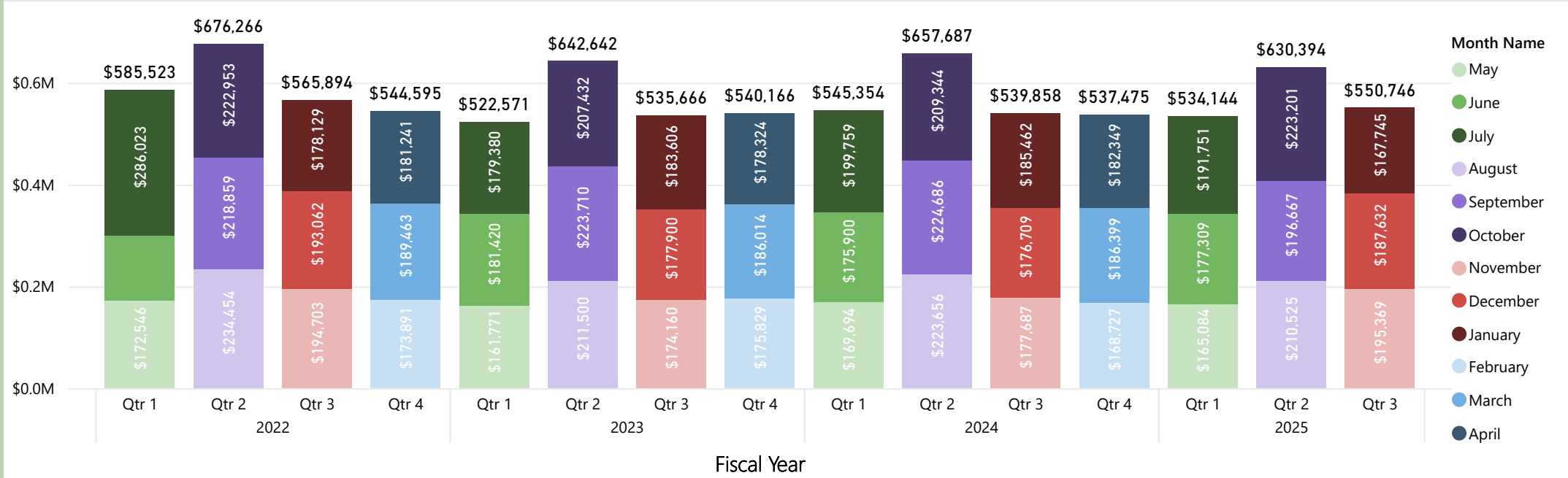

## Sewer Usage Revenue by Month

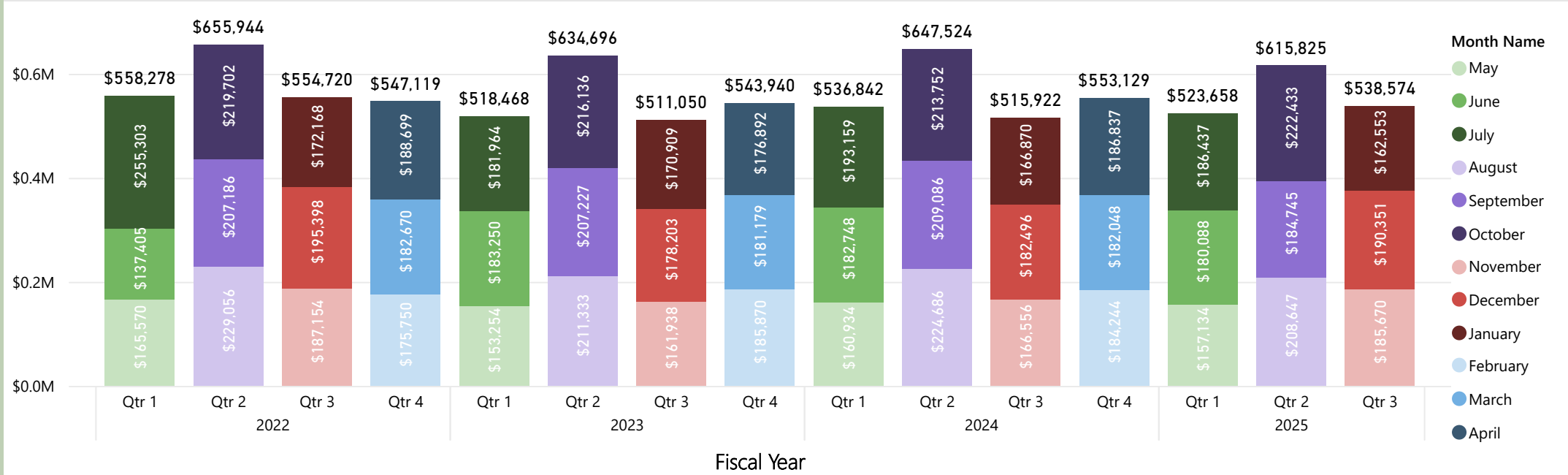

## General Fund Historical Revenues

FY	Month Name	Property Tax	Sales Tax	Income Tax	Fines & Forfeits	Building Permits	Simplified Municipal Tax	Other Revenues
2025	May	\$20,084	\$138,089	\$387,591	\$2,247	\$76,679	\$10,414	\$100,921
2025	June	\$209,488	\$161,019	\$167,110	\$9,824	\$87,044	\$9,181	\$39,088
2025	July	\$5,436	\$165,368	\$242,292	\$3,931	\$165,946	\$8,896	\$40,859
2025	August	\$10,117	\$164,068	\$162,514	\$3,371	\$53,211	\$8,985	\$80,119
2025	September	\$185,016	\$154,072	\$127,859	\$3,134	\$81,006	\$9,095	\$40,130
2025	October	\$18,138	\$166,564	\$271,078	\$4,646	\$51,550	\$9,137	\$47,028
2025	November	\$1,994	\$166,855	\$163,395	\$6,852	\$21,729	\$9,032	\$82,622
2025	December	\$6,262	\$166,847	\$127,974	\$5,493	\$11,084	\$9,017	\$39,041
2025	January	\$0	\$153,809	\$265,283	\$1,910	\$11,603	\$9,160	\$38,116

## Actual Fiscal Year 25 Revenue Compared to Budget

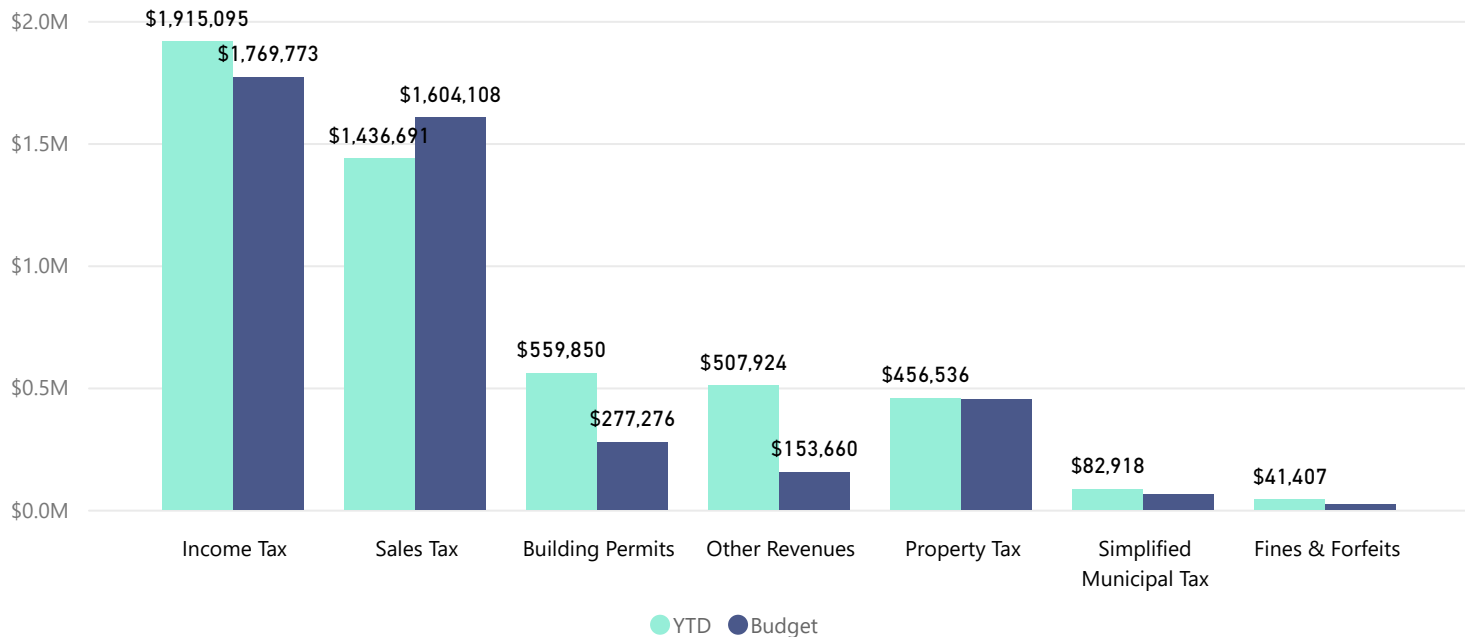

Revenues	YTD	Budget	% of Budget
Building Permits	\$559,850	\$277,276	201.91 %
Fines & Forfeits	\$41,407	\$24,225	170.93 %
Income Tax	\$1,915,095	\$1,769,773	108.21 %
Other Revenues	\$507,924	\$153,660	330.55 %
Property Tax	\$456,536	\$450,069	101.44 %
Sales Tax	\$1,436,691	\$1,604,108	89.56 %
Simplified Municipal Tax	\$82,918	\$63,856	129.85 %

## Water/ Sewer fund Historical Revenues

FY	Month Name	Water Usage	Sewer Usage
2025	May	\$165,084	\$157,134
2025	June	\$177,309	\$180,088
2025	July	\$191,751	\$186,437
2025	August	\$210,525	\$208,647
2025	September	\$196,667	\$184,745
2025	October	\$223,201	\$222,433
2025	November	\$195,369	\$185,670
2025	December	\$187,632	\$190,351
2025	January	\$167,745	\$162,553

## Actual FY25 Revenue Compared to Budget

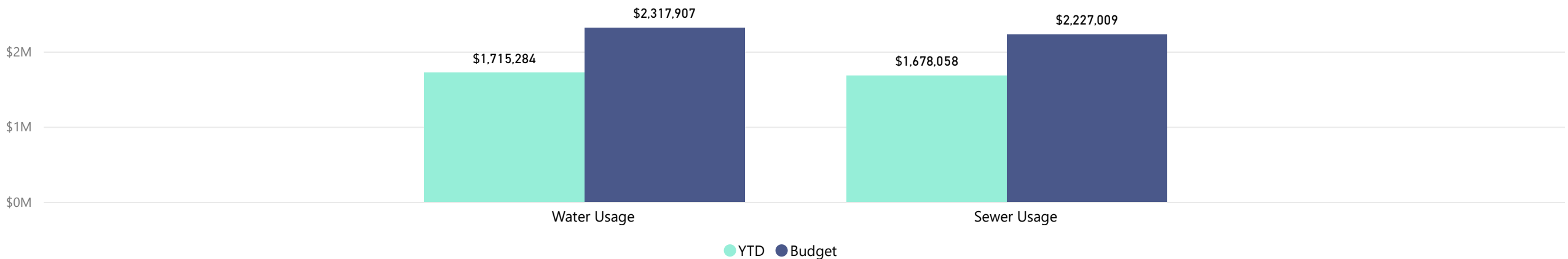

Revenues	YTD	Budget	% of Budget
Sewer Usage	\$1,678,058	\$2,227,009	75 %
Water Usage	\$1,715,284	\$2,317,907	74 %



## MEMORANDUM

**DATE:** February 7, 2025

**TO:** Mayor Marturano and the Village Board of Trustees

**FROM:** Clay T. Johnson, Village Administrator

**RE:** **Regular Village Board Meeting Agenda Transmittal for February 10, 2025**

### New Business

**A. Resolution 25-2-2308R: Approving and Making a Determination on Executive Session Meeting Minutes and Verbatim Recordings**

Pursuant to state statute, the Village Board has performed its semi-annual review of executive session minutes for possible release to the public. Only those executive session minutes which are identified in the resolution are recommended to be approved for content and released.

**B. Approval: Request from S.T.U.D.Y.S. Ministries at 656 Bridgeport Terrace for Relief from Signage Code to Install a LED Sign**

The Village has received a request from S.T.U.D.Y.S. Ministries, owner of the westernmost in-line retail building at Waterford Commons, for the Village to provide relief from the area, zoning district, and distance requirements established by Village Code.

The signage in question is the smaller, and more easterly installed changeable copy sign for the complex. An aerial provided within the requestor's materials shows the location of the sign. The proposed LED signage would replace all of the changeable copy tiles within the current sign with an LED signage cabinet of about 60 sqft in area. The location of the sign is such that it sits directly across from a residential use which exists south of Grass Lake Road. However, the sign is closer than the 100-foot distance buffer needed between the LED signage and a residential use. Finally, per LED signage regulations, such signs are only permitted in CB, CBR-2, RO, and I zoning districts. Waterford Commons which includes all of S.T.U.D.Y.S. Ministries' properties, the inline retail building east of the building in question containing Lucky Penny's and Grass Lake Grocery, and Brainstorm are all in the NB Zoning District. Each of those other properties have their own monument signage.

As requested, there are three standards requiring relief from the Village's LED sign standards:



Village Code Standard per 157.0800	Relief Requested
(D) Free Standing Sign Area Cannot Exceed 40 square feet	60 square feet
(O) LED Signs only permitted in CB, CBR-2, RO, I districts	NB District
(Q) No LED Sign shall be located within 100 feet of a residential use.	Appr. 85 feet

There is a reasonable argument to be made that the orientation of this particular business is detrimental to the visibility of passersby on Grass Lake Road. While wall signage does exist on the rear of the building to denote certain businesses, it is non-illuminated. Vehicular traffic may not take as much notice of this side of the building since it doesn't appear to have Grass Lake Road frontage.

It should also be noted that this sign is not the only sign within this complex. There is a larger monument sign for the center at the intersection of N. Beck Road and Grass Lake Road. The inline building to the west of S.T.U.D.Y.S. has its own signage, as does Brainstorm. All of those signs are very comparable to each other in size, shape, and color. There are actually five monument signs for the entire complex with four on Grass Lake Road and one on N. Beck. The four Grass Lake Road signs are all within 635 feet of each other along the right-of-way. However, the two of the five signs are on parcels with different owners. I think it's fair to wonder if approving relief for this particular sign would open the door for similar requests from those property owners or for signage along a different roadway.

Staff doesn't have opposition to the request per se, but consideration should be made with the larger picture in mind. Has the applicant spoken to the other owners about how this sign could affect their desire for similar signage? Could a planned signage district be worked out for all owners? The Village likely would not support four (4) LED signs being installed within approximately 650 feet of each other. The different owners all may want different orientations of the LED cabinets or different sizes. If possible, uniformity for the entire complex as exists today should be desired.

Staff suggests that the applicant seek to gain support for the installation of a single LED sign for the complex to serve as many willing parties as possible. This may allow for the consolidation of signs which would be a net positive. Could the large monument sign at the corner of N. Beck and Grass Lake be exchanged for a smaller LED sign representing all users? Meanwhile, staff would like the opportunity to research LED signage regulations from other communities. The nature and, in some cases, the acceptance of LED signage has changed since 2011 when this ordinance was last reviewed and approved. More research should be sought into how other communities regulate this type of signage in various zoning districts and applications.



**C. Approval: Public Works Wastewater Treatment Facility Building Roof Repairs – Waukegan Roofing - \$79,695**

The FY 2025 budget includes the replacement/repair of the roof at the Public Works buildings at the wastewater treatment facility off of Grass Lake Road. This work includes many of the accessory buildings which were built as part of the facility's previous expansion in the 1990s. Staff sought bids from Waukegan Roofing and received a quote of \$51,850 for the work, well under the \$120,000 budgeted. Because of this savings versus our budget, Public Works inquired about the cost of repairing other buildings' roofs that are reaching their end of life. Public Works was specifically concerned with the well house on High Point Drive. The cost for this additional work at came to \$20,600.

If approved, the total cost of all roofing repairs came to \$72,450. This figure includes work at the wastewater treatment facility and the well house on High Point Drive. Public Works is also requesting a 10% contingency for this project to account for unknown repairs that may need to be addressed as the old roof systems are replaced. With contingency, the total amount of the project would be at a cost not to exceed \$79,695.

The Village has a long history with Waukegan Roofing and uses them often for repairs. We have found their quotes to be at, or better than, what we've been able to obtain through other providers. They also consistently remain within our not-to-exceed spending limits. As we only received one quote for this work, but believe it to be very competitive, we are asking the Village Board to waive the bidding requirements for this work and award the project to Waukegan Roofing at a cost not to exceed \$79,695.

**D. Approval: Public Works 5-Ton Truck Replacement Purchase - \$222,728**

If we continue to follow Public Works' vehicle replacement schedule in FY 2026, the fleet is to have replaced a 5-Ton dump truck. Public Works has done considerable work in rethinking its fleet by replacing many of the 5-ton dump trucks with low-profile dump trucks, like Ford F650s. Not only do those vehicles cost less to purchase and outfit, they are more flexible, allowing for more everyday use. Additionally, they do not require possession of a Commercial Driver's License to operate. This gives our staff flexibility in who drives certain trucks when our snow plow operations are underway.

Here Public Works is recommending the replacement of this 5-ton dump truck with another. There will always be a need for 5-ton dump trucks within our operation. These trucks allow for better hauling of large quantities of materials. They also have the weight and horsepower needed to better handle heavier snows within certain Village plowing zones.

Like with an approach taken by the Police Department with the ordering of their squads, Public Works is seeking authorization to move forward with the ordering of a replacement



5-Ton dump truck. Production of these large trucks have much of the same lead time as our police squad vehicles, if not greater. Production of this vehicle could take up to eighteen (18) months. Public Works has sought costs for the replacement of their fleet vehicle, which comes in at a cost of \$222,728. This cost figure comes in under what was originally forecasted for FY 2026 - \$233,466.

Authorization of this purchase would lock us in at the cost figure cited above and be programmed into the FY 2026, or FY 2027, budget depending on expected delivery. More detail about the vehicle can be ascertained in the enclosed memorandum from Public Works.



February 10, 2025

# Village Board Meeting Agenda Item Cover Sheet

Agenda Item: A. Resolution 25-2-2308R: Approving and Releasing Certain Executive Session Minutes

Alignment with Strategic Plan:

- C** Community Branding & Engagement
- G** Responsible Growth & Development
- F** Future Ready Operations
- I** Capital Infrastructure Planning & Improvements
- B** Business Recruitment & Retention
- U** Operational/Unaffiliated

Budgetary Impact: N/A

Within Budget:  Yes  No

---

---

Suggested Motion: **Approve Resolution 25-2-2308R: approving and making a determination on certain executive session meeting minutes and recordings.**

Voting Record:

- |                          |                   |                          |                 |
|--------------------------|-------------------|--------------------------|-----------------|
| <input type="checkbox"/> | Trustee Chybowski | <input type="checkbox"/> | Trustee Rosten  |
| <input type="checkbox"/> | Trustee Dickson   | <input type="checkbox"/> | Trustee Suchy   |
| <input type="checkbox"/> | Trustee Dunham    | <input type="checkbox"/> | Mayor Marturano |
| <input type="checkbox"/> | Trustee Grace     |                          |                 |

**RESOLUTION NO. 25-2-2308R**

**A RESOLUTION APPROVING AND MAKING A DETERMINATION ON EXECUTIVE SESSION MEETING MINUTES AND VERBATIM RECORDINGS**

**WHEREAS**, the Village Board of Trustees of the Village of Lindenhurst, has met from time to time in executive session for purposes authorized by the Illinois Open Meetings Act; and

**WHEREAS**, pursuant to 5 ILCS 120/2.06, on July 25, 2022, the Village Board conducted a review and approval of executive session meeting minutes and has determined that certain executive session minutes should be released to the public; and

**WHEREAS**, the Village Board has determined that certain executive session minutes not yet released should remain confidential, subject to further review and determination as to their appropriateness for release at a future date; and

**WHEREAS**, the Village Board has also determined that certain verbatim recordings of executive session minutes for meetings that occurred at least 18 months ago and for which minutes have been approved are ready for destruction pursuant to Section 2.06(c) of the Act.

**NOW, THEREFORE, BE IT RESOLVED** by the Mayor and Board of Trustees of the Village of Lindenhurst, Lake County, Illinois, as follows:

**SECTION 1.** The Village Board of Trustees hereby determines that the following executive session meeting minutes should be approved for content:

<b>APPROVED FOR CONTENT</b>
June 24, 2024

**SECTION 2.** The Village Board of Trustees hereby determines that the following approved executive session meeting minutes should now be released to the public:

<b>APPROVED FOR RELEASE TO PUBLIC</b>
June 24, 2024

The Board has further determined that all executive session meeting minutes that have not yet been approved for release to the public should remain confidential at this time, subject to further review and determination as to their appropriateness for release at a future date.

**SECTION 3.** The Village Board of Trustees hereby determines that verbatim recordings of executive session meetings that occurred at least 18 months ago and for which minutes have been approved are ready for destruction, and hereby directs the Village Administrator to destroy these recordings without further action or approval by the Board:

**SECTION 4.** This Resolution shall take effect immediately upon its passage and approval as provided by law.

**PASSED AND APPROVED** by the Mayor and Board of Trustees of the Village of Lindenhurst, Illinois, this 10<sup>th</sup> day of February, 2025.

DOMINIC MARTURANO, MAYOR

**ATTEST:**

Melissa Forsberg, Village Clerk

**TRUSTEES**

**AYE**

**NAY**

Patty Chybowski

\_\_\_\_\_

\_\_\_\_\_

Patrick Dickson

\_\_\_\_\_

\_\_\_\_\_

Patrick Dunham

\_\_\_\_\_

\_\_\_\_\_

Ronald Grace

\_\_\_\_\_

\_\_\_\_\_

Heath Rosten

\_\_\_\_\_

\_\_\_\_\_

Dawn Suchy

\_\_\_\_\_

\_\_\_\_\_



February 10, 2025

# Village Board Meeting Agenda Item Cover Sheet

Agenda Item: B. Request from S.T.U.D.Y.S. Ministries for Relief from LED Signage Regulations

Alignment with Strategic Plan:

- C** Community Branding & Engagement
- G** Responsible Growth & Development
- F** Future Ready Operations
- I** Capital Infrastructure Planning & Improvements
- B** Business Recruitment & Retention
- U** Operational/Unaffiliated

Budgetary Impact: N/A

Within Budget:  Yes  No

---

---

Suggested Motion: **Approve the request from S.T.U.D.Y.S. Ministries for relief from the zoning district, size, and distance buffer requirements from Section 157.0800 of the Village Code.**

Voting Record:

- |                          |                   |                          |                 |
|--------------------------|-------------------|--------------------------|-----------------|
| <input type="checkbox"/> | Trustee Chybowski | <input type="checkbox"/> | Trustee Rosten  |
| <input type="checkbox"/> | Trustee Dickson   | <input type="checkbox"/> | Trustee Suchy   |
| <input type="checkbox"/> | Trustee Dunham    | <input type="checkbox"/> | Mayor Marturano |
| <input type="checkbox"/> | Trustee Grace     |                          |                 |



S.T.U.D.Y.S. Ministries  
656 N. Bridgeport Ter.  
Lindenhurst, IL 60046

January 25, 2025

Clay Johnson, Lindenhurst Village Planner  
2301 Sand Lake Road  
Lindenhurst, IL 60046

Dear Mr. Johnson,

The intent of this letter is to request a variance waiver that will enable the installation of a small digital sign at 616 N Bridgeport Terrace, Lindenhurst.

The current signage, located on Grass Lake Road, is outdated and unable to serve the commercial business awareness needs of the mall tenants. The business related urgency/imperative of this request is threefold:

- First, Mall business in general is tough these days. As you are certainly aware, the latest data shows a decline in mall traffic/business due to the emergence of Amazon and other online ordering platforms. We have not been exempt from this phenomenon and seek your help in this matter.
- Second, the mall at 616 N Bridgeport is already at a strategic disadvantage because it was constructed to face inward, which doesn't allow patrons/potential patrons to actively view the businesses that are located there. Additionally, patrons are inconvenienced by being required to drive around back to park and utilize the businesses. I understand there is nothing we can do about that, except to somehow compensate for poor visibility of these businesses.
- Third, the latest marketing research - we had conducted three months ago - shows that we are severely underutilizing the viewership of the approximately 9,300 vehicles that traverse Grass Lake Road every day!

The new sign is unassuming and aesthetically appealing. It will replace, almost inch for inch, the current signage. (Pictures of both the current sign and the future sign are attached). Lastly, the sign would not intrude on any of the surrounding residences, which are all hundreds of feet away from the sign location.

Thriving small businesses are at the heart of any community's vibrancy and economic health. We continue to work hard to beautify our mall and keep it at 100% occupancy, which it has been at for over two years. The property and revenue taxes collected from these businesses ensure the continued success of OUR Village!

Please help our tenants grow the awareness of their businesses with our community and those who travel through it.

Please don't hesitate to let me know if you have any additional questions or need any additional information. My direct line is below.

Sincerely,

A handwritten signature in black ink, appearing to read 'Ernest L Duplessis Senior'. The signature is fluid and cursive, with a large loop at the end.

Ernest L Duplessis Senior  
President and Senior Pastor STUDYS Ministries  
Direct Line - (847) 226-9259

# STUDY Ministries

616 N Bridgeport Terrace, Lindenhurst, IL 60046

## Retrofit

6'x10' 9mm double-sided display

## Project ID:

Revision 1 - 1/23/25

Project Manager: Joshua Bleigh

Sales Rep: Chase Maddox



# Your New Cirrus Display

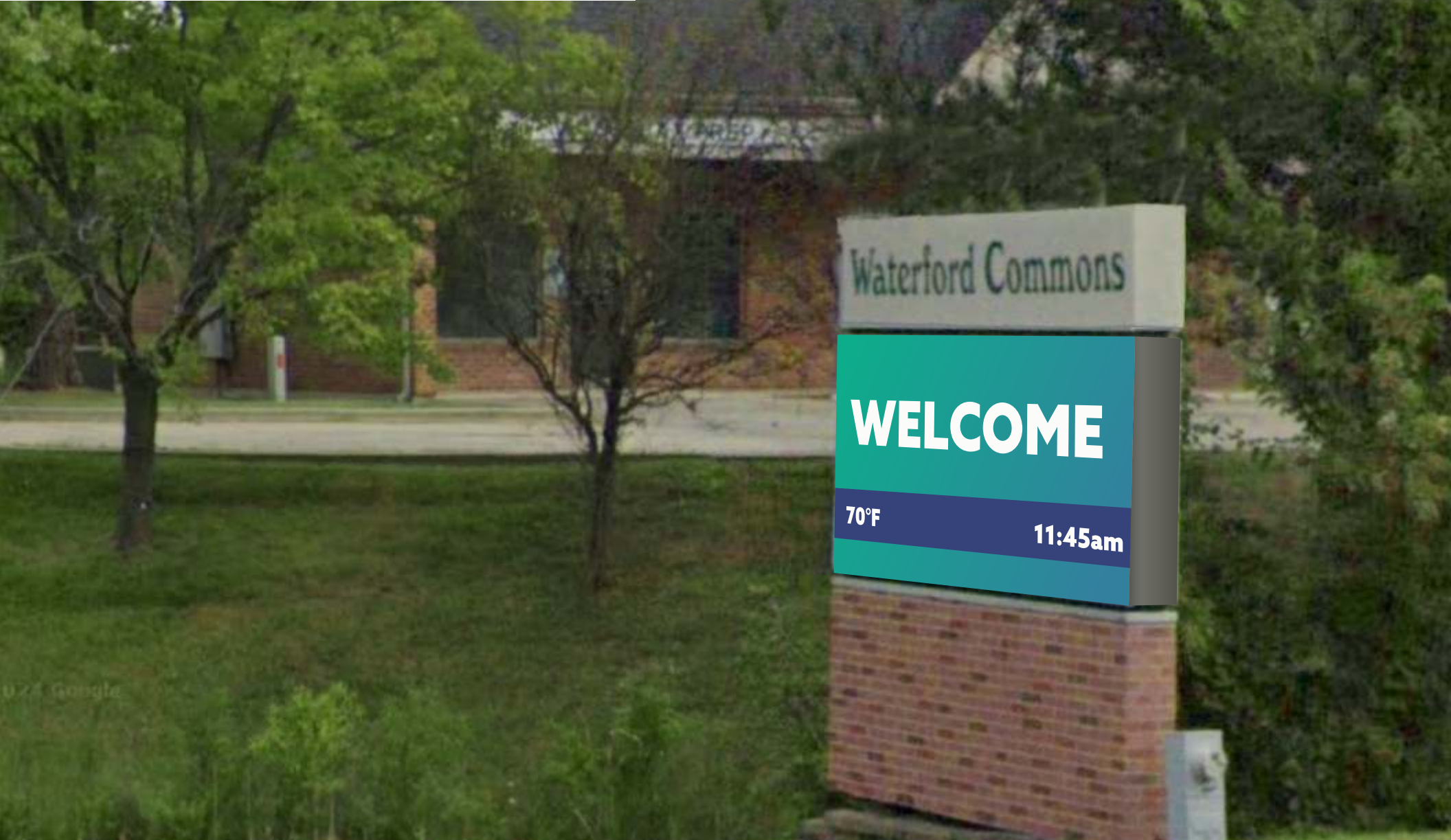

© 2014 Google



Cirrus Systems 200 West Rd. Portsmouth, NH 03801  
Tel (877) 636-2331 Email [info@cirrusled.com](mailto:info@cirrusled.com)

**STUDY Ministries** - Retrofit  
616 N Bridgeport Terrace, Lindenhurst, IL 60046

## EXISTING SITE



## PROPOSED DISPLAY

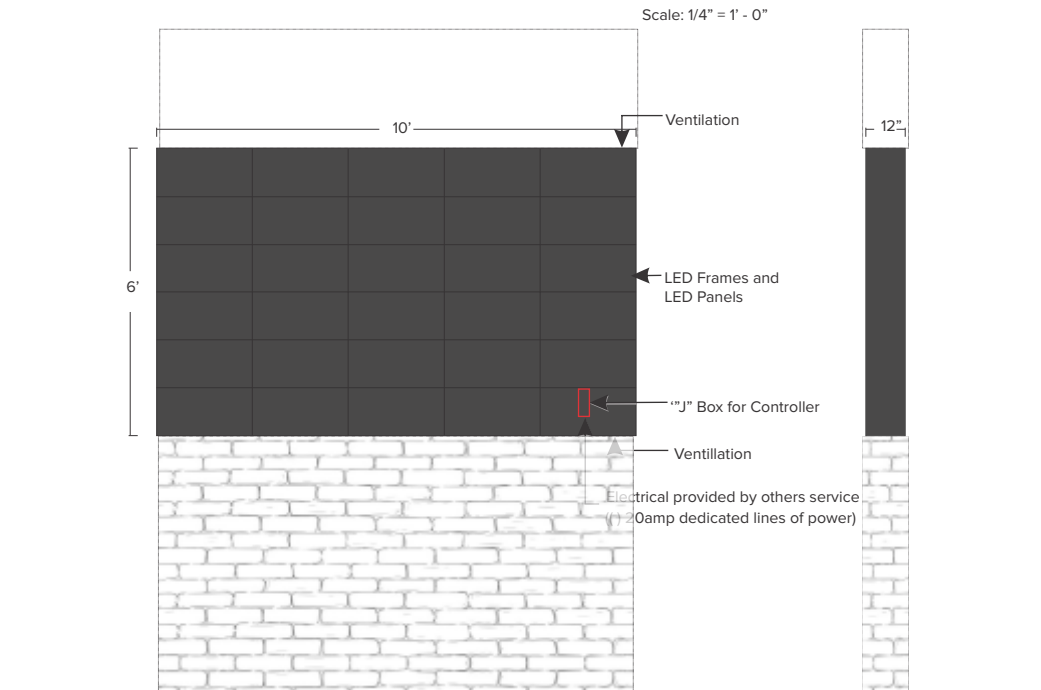
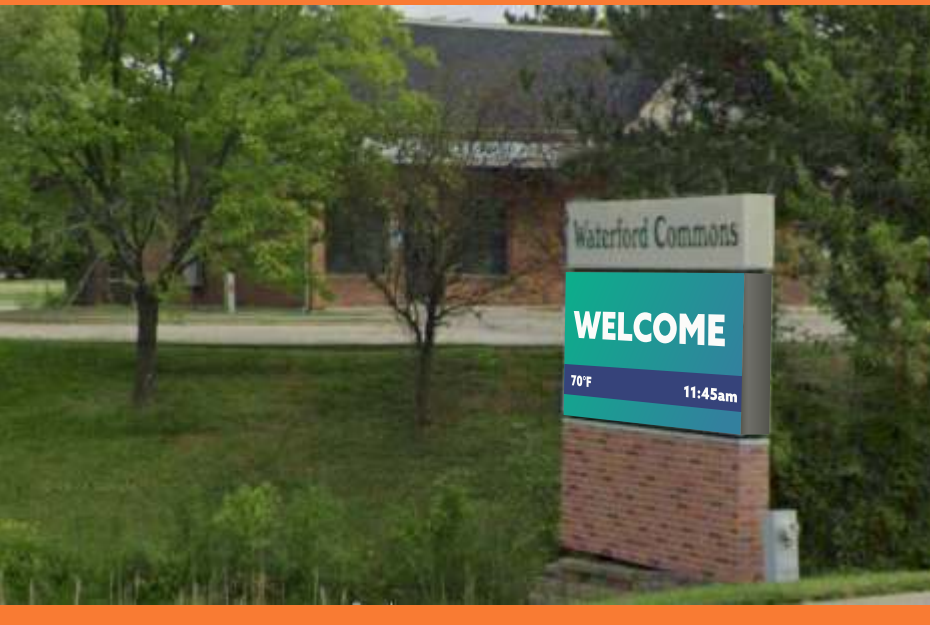

### SCOPE OF WORK:

- Receive, Inspect and Assemble 6'x10' 9mm double sided Cirrus EMC. Replace existing cabinet with new display

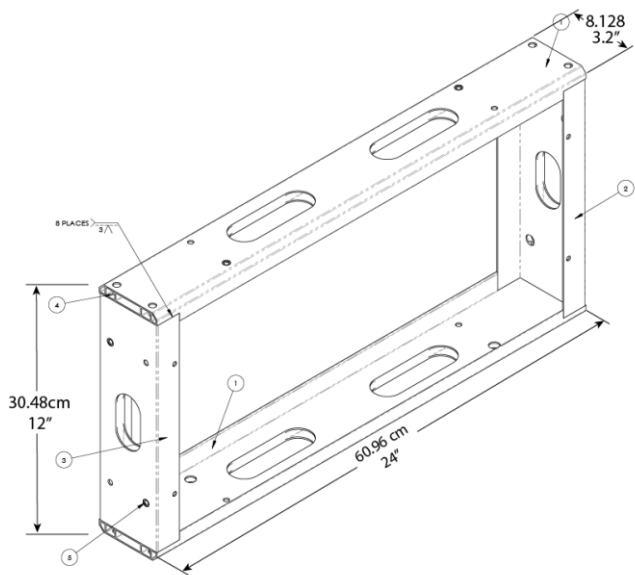

### Features

- Solid-state technology
- IP65 rated with built-in power supply
- Future-proof modular architecture
- 24-48 hour turnaround time

### Specs

- High-strength extruded aluminum frame
- Total: W 24" / H 12" / D 4 1/8" / Weight 11.2 lbs.
- Panel: D 7/8" / Weight 6.12 lbs.

### Includes

- Aluminum frames and hex bolts
- LED modules and controller
- Power and data cables
- ScreenHub software + lifetime training & support

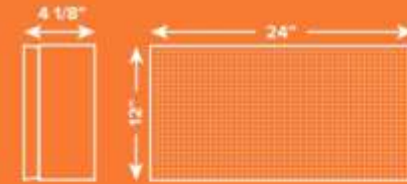

### Static Cabinet Integration

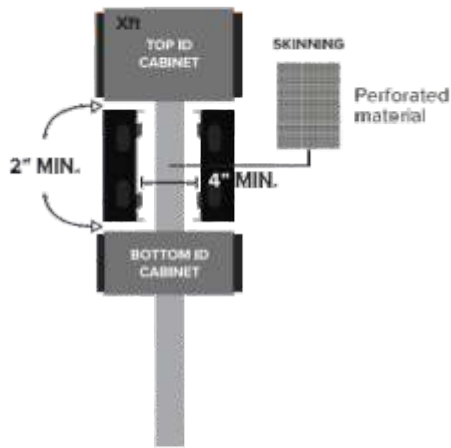

2" MIN. space required on top and bottom of the display required to meet warranty. To increase convection, the sides of the display can be left open or covered with a perforated material.

### Monument or integrated



2" MIN. of space around LED sign

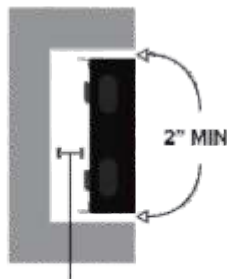

4" MIN. when recessed

COLOR	281 Trillion
RESOLUTION (PITCH)	12, 9, 6, and 4mm
BRIGHTNESS (NITS)	7500
PANEL DIMENSIONS	24"W / 12"H / 4 1/8"D / 11.2 lbs
MODULE MATRIX	12mm 24x48 / 9mm 32x64 / 6mm 48x96 / 4mm 64x128
MAX WATTS PER PANEL	12mm 70W / 9mm 105W, 6mm 115W, 4mm 130W
MIN VIEWING DISTANCE	12mm 20ft / 9mm 12ft / 6mm 8ft / 4mm 4ft
VIEWING ANGLE	160° Horizontal / 90° Vertical
REFRESH RATE	24-60 FPS (dependant on display size)
AC INPUT	Universal AC input (90-264VAC input range)
TEMPERATURE RATING	-40°-158° Fahrenheit
WIFI CONNECTION	TP Link long-range high power bridge
CELLULAR BROADBAND	5 Year cellular broadband available
DISPLAY LIFE SPAN	100,000 Hours
WARRANTY	5-year limited hardware / 5-year service (optional)
APPROVALS	FCC, UL 897, CAN/CSA-C22.2 No 207-M89



Cirrus Systems, Inc.  
 200 West Rd.  
 Portsmouth, NH 03801  
[www.cirrusled.com](http://www.cirrusled.com)  
 877-636-2331

Client Name & Address:

Date:

© Cirrus Systems, Inc. This drawing was created to assist you in visualizing our proposal. The original ideas herein are the property of © Cirrus Systems, Inc. Permission to copy or revise this drawing can only be obtained through a written agreement with © Cirrus Systems, Inc. See your account representative or contact your nearest office.

**Electrical:**

The digital display must be on a separate circuit from the backlit cabinet. Please reference the manual for electrical specifications.

**Power Requirements:**

Volts	Pitch	Mods	Sides	Lines of Power
	9mm	60	2	

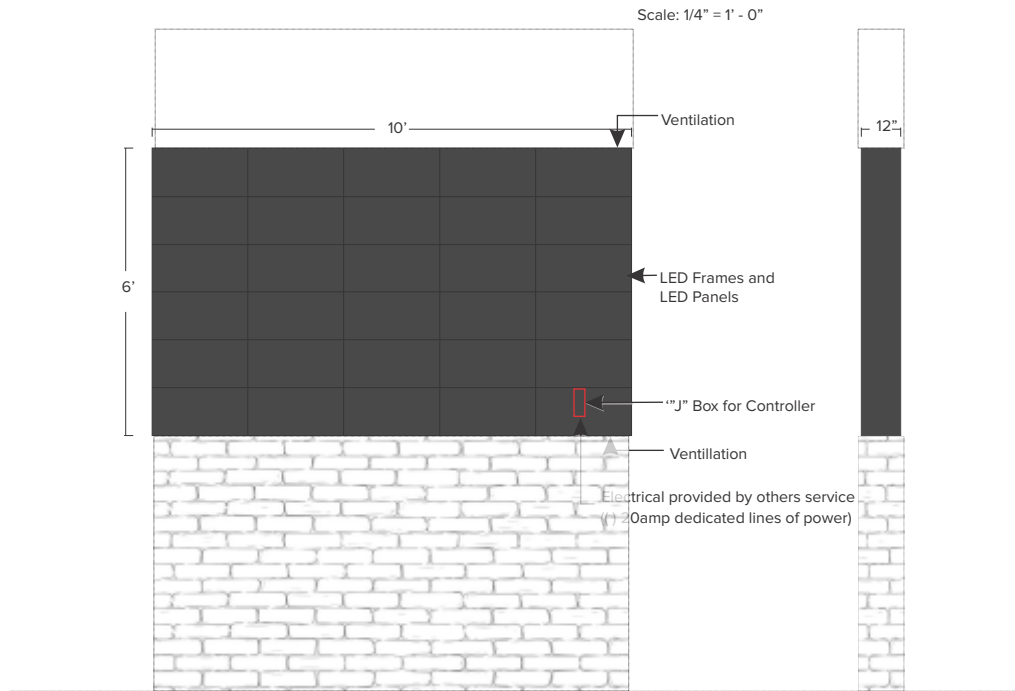

Cirrus Systems 200 West Rd. Portsmouth, NH 03801  
 Tel (877) 636-2331 Email [info@cirrusled.com](mailto:info@cirrusled.com)

**STUDY Ministries - Retrofit**  
 616 N Bridgeport Terrace, Lindenhurst, IL 60046



Sign will be installed here:

**Parcel Highlights**

Full Address  
**0 N Bridgeport Ter,  
 Lindenhurst, IL 60046**

Measurements  
 0.53 Acres

Owner  
 WATERFORD COMMONS COMMERCIAL OWNERS ASSN

Zoning type  
 Neighborhood Business District

Land Use  
 Comm Vacant Land

**Parcel Details**

Parcel ID  
 0225310002

Parcel Address  
 0 N BRIDGEPORT TER

Parcel Address City  
 LINDENHURST

Parcel Address Zip Code  
 60046



Customer Approval  
 Signature:  
 Date:

***Thank You!***



February 10, 2025

# Village Board Meeting Agenda Item Cover Sheet

Agenda Item: C. Public Works Wastewater Treatment Facility Building Roof Repairs

Alignment with Strategic Plan:

- C** Community Branding & Engagement
- G** Responsible Growth & Development
- F** Future Ready Operations
- I** Capital Infrastructure Planning & Improvements
- B** Business Recruitment & Retention
- U** Operational/Unaffiliated

Budgetary Impact: \$79,695 from Community Capital

Within Budget:  Yes  No

Suggested Motion: **Waive the bids and authorize the Village Administrator to enter into a service agreement with Waukegan Roofing in an amount not to exceed \$79,695**

Voting Record:

- |                          |                   |                          |                 |
|--------------------------|-------------------|--------------------------|-----------------|
| <input type="checkbox"/> | Trustee Chybowski | <input type="checkbox"/> | Trustee Rosten  |
| <input type="checkbox"/> | Trustee Dickson   | <input type="checkbox"/> | Trustee Suchy   |
| <input type="checkbox"/> | Trustee Dunham    | <input type="checkbox"/> | Mayor Marturano |
| <input type="checkbox"/> | Trustee Grace     |                          |                 |



DATE: February 7, 2025

TO: Clay Johnson, Village Administrator

FROM: Charles Hernandez, Utility Systems Manager

RE: Public Works Roof Repairs - Waive of Bids

Public Works is requesting to waive the bid process for the required roof replacement/repairs at the Waste Water Treatment Facility. The four buildings are the Influent Station (Bld. H), Blower Building (Bld. J), RAS/WAS Building (Bld. R), and Filter Building (Bld. S). These buildings were part of the 1991 plant expansion with the roofs surpassing their 30-year shingle life. At present, three of the four buildings had leaks that were spot repaired in the past two years. The proposed work entails the removal of the shingles and underlayment to expose the plywood decking, replace damaged plywood, install new underlayment and shingles. Additionally; gutter apron flashing, drip edge, exhaust boot, flashing tins, and ridge vents will be replaced as recommended on the buildings.

Waukegan Roofing has been servicing the roofs at the Wastewater Treatment Facility and the Village Hall for some time. We have developed a good working relationship with their staff and call them when spot repairs are needed. Waukegan Roofing has the staff and materials needed for the repairs and are prepared to begin once the temperatures warm above 45 degrees.

During the last site visit, it was identified that some soffit and drip edges on the Operations Building are in need of repair/replacement. We also identified repairs at the Highpoint Well House and are requesting to add these repairs in as part of the project. Based on the \$120,000 budgeted amount for the Treatment Plant repairs and the quote of \$51,850 for actual work at the Treatment Plant, Public Works is requesting to complete the additional work as a package with Waukegan Roofing.

Due to the nature of the work, exact decking replacement is unknown until the shingles and underlayment are removed. We propose a 10% contingency to pay for these costs to be added to the final price if needed. The following is a breakdown of the proposed costs:

Building	Cost
<b>Influent Station (Bld. H)</b>	\$17,250
<b>Blower Building (Bld. J)</b>	\$10,600
<b>RAS/WAS &amp; Filter Building (Bld. R&amp;S)</b>	\$24,000
<b>Highpoint Well House 2</b>	\$15,700
<b>Highpoint Well House 2</b>	\$4,900

	<b>Total</b>	<b>\$72,450</b>
	<b>10% Contingency</b>	<b>\$7,245</b>
	<b>Ext. Total</b>	<b>\$79,695</b>

With your approval, Public Works would like to enter into an agreement with Waukegan Roofing to complete the necessary repairs at the Waste Water Treatment Facility and the Highpoint Well House in the amount of \$79,695.

### WWTF - LOCATIONS

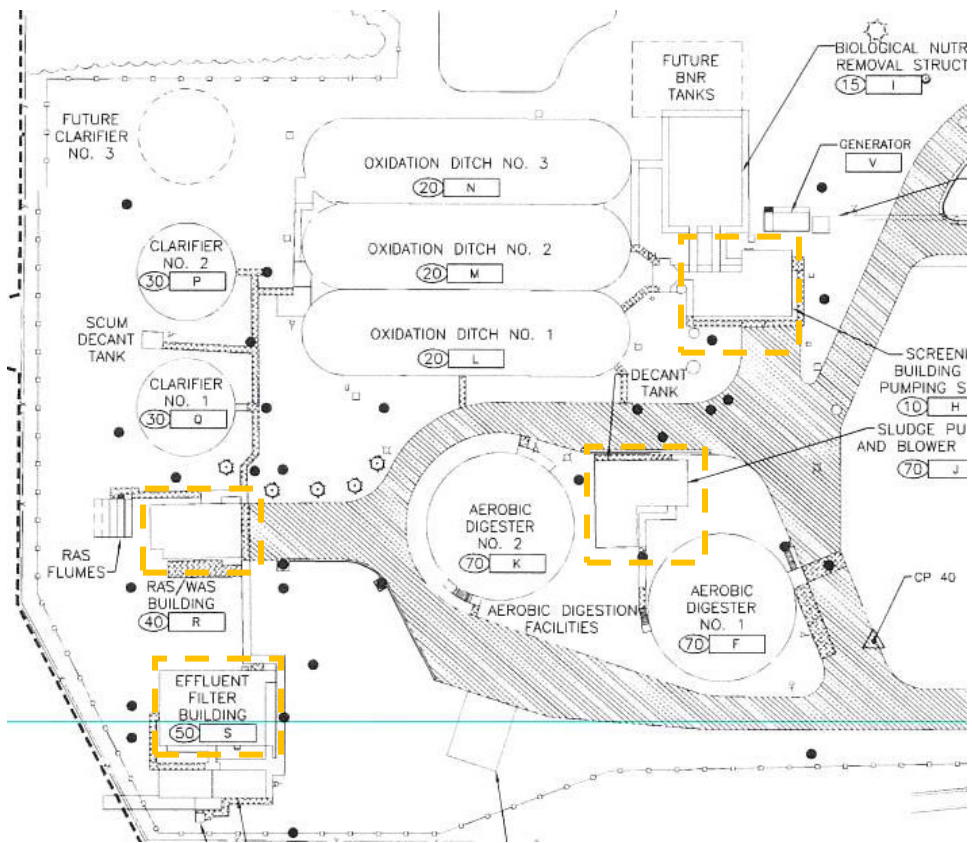

# WAUKEGAN ROOFING CO., INC.

Date: February 13, 2024

Quoted To: Village Of Lindenhurst  
2060 Grass Lake Rd  
Lindenhurst, IL 60046

Attention: Mike Turner  
Email: [mturner@lindenhurstil.org](mailto:mturner@lindenhurstil.org)  
Phone Number: 815-861-7354

Project Name: Sanitary Buildings H, J, R, S @  
2060 Grass Lake Rd  
Lindenhurst, IL 60046

*Thank you for calling Waukegan Roofing Co., Inc. and requesting that our firm provide an estimate to replace the existing roofing system on your building. Please review the enclosed proposal and call me to discuss any questions or concerns you may have.*

**Our Proposal is based on the information shown below and on the following pages all inclusive:**

- **This proposal, if accepted, is the Contract Document**
- **The prices set forth in this proposal are good for 30 days from the date shown at the top of this page.**
- **Prior to finalizing any proposal documents after that date may be cause for these proposed prices to be increased to reflect the additional material and transportation costs extended to the contractor.**
  - This Proposal / Contract is based upon your request for our firm to visit the site to measure and evaluate the condition of the existing roofing system and from the information obtained during our discussions while on-site.
  - If additional work is requested or required beyond the Scope of Work described herein said work shall be charged as an extra to the Proposal / Contract price shown below.

### **Important Considerations for the Project:**

- ✓ For the safety and protection of any valuable personal belongings and property, inventory items, items stored on shelves, light fixtures, security, smoke or fire alarms or wall hangings we recommend that you, the owner, cover, remove or store those items before and during the course of completing this project.
- ✓ Prior to starting the removal of the existing roofing system(s):
  - We will have a "roll off" dumpster delivered and positioned on the pavement and wood boards will be placed beneath the wheels of the dumpster box.
  - We will have the new roofing materials and accessories delivered, stored on the jobsite
- ✓ Then the layers of the existing roofing system(s) along with the sheet metal flashings, will be removed by hand, or lifted with a crane, and will be dumped into the "roll off" dumpster.
- ✓ Throughout the course of the work day:
  - As the dumpster gets filled it will be hauled away
  - The pavement and lawn will be raked clean
  - A rolling magnet will be used to pick up metal scraps and nails in the area.
- ✓ We will leave the property in a broom clean condition at the end of work day.
- ✓ It should be expected that:
  - The accumulated water and moisture currently trapped and absorbed into the existing roofing system(s) may become dislodged and enter the building during the demolition process
  - The accumulated dust and dirt in the existing ceiling and attic spaces may become loose and fall into building and onto the floor.
  - This type of clean-up will be the responsibility of the Authorized Signee / Owner at no cost or expense to Contractor.



956 Campus Dr • Mundelein, Illinois 60060  
Phone: 847-623-1625 • Fax: 847-623-4847  
[www.waukeganroofing.com](http://www.waukeganroofing.com) • IL License #104-000761



# WAUKEGAN ROOFING CO., INC.

**Our Proposal is described below: Building H**

**Waukegan Roofing Co., Inc. proposes to supply the:**

- Labor, insurance, materials, tools and equipment required to remove the existing layer of roofing shingles, underlayment felts and vents down to the roof deck.
- We will remove the roofing related debris from the jobsite and properly dispose of it in a State registered landfill.
- Asphalt Saturated Felt Underlayment will be installed on the remaining roof deck not previously covered with ice and water shield
- CertainTeed Swift Start Self Sealing starter strip shingles will be installed where required.
- *CertainTeed Landmark™* Shingles with a *Limited Lifetime material warranty* will be installed along with matching *CertainTeed Shadow Ridge™* hip and ridge shingles
  
- The following products will also be installed in conjunction with the products listed above:
  - New Prefinished steel Gutter apron flashings will be installed at all the gutter edges.
  - New Prefinished steel drip edge along all rake edges.
  - New plumbing exhaust vent boots at all plumbing vent stacks.
  - New 4x4x8 flashing tins at all the roof to wall intersections.
  - Air vent ridge vent II along the ridge lines.
  
- ***CertainTeed 3-Star SureStart™ Warranty is included in this proposal.***
- ***Waukegan Roofing Co., Inc. 2-year Workmanship Warranty is included in this proposal***

**Base Proposal Price for the work described above is \$ 17,250.00 \_\_\_\_\_**

**Our Proposal is described below: Building J**

**Waukegan Roofing Co., Inc. proposes to supply the:**

- Labor, insurance, materials, tools and equipment required to remove the existing layer of roofing shingles, underlayment felts and vents down to the roof deck.
- We will remove the roofing related debris from the jobsite and properly dispose of it in a State registered landfill.
- Asphalt Saturated Felt Underlayment will be installed on the remaining roof deck not previously covered with ice and water shield
- CertainTeed Swift Start Self Sealing starter strip shingles will be installed where required.
- *CertainTeed Landmark™* Shingles with a *Limited Lifetime material warranty* will be installed along with matching *CertainTeed Shadow Ridge™* hip and ridge shingles
  
- The following products will also be installed in conjunction with the products listed above:
  - New Prefinished steel Gutter apron flashings will be installed at all the gutter edges.
  - New Prefinished steel drip edge along all rake edges.
  - New plumbing exhaust vent boots at all plumbing vent stacks.
  - New 4x4x8 flashing tins at all the roof to wall intersections.
  - Air vent ridge vent II along the ridge lines.
  
- ***CertainTeed 3-Star SureStart™ Warranty is included in this proposal.***
- ***Waukegan Roofing Co., Inc. 2-year Workmanship Warranty is included in this proposal***

**Base Proposal Price for the work described above is \$ 10,600.00 \_\_\_\_\_**

**Our Proposal is described below: Building R&S**

**Waukegan Roofing Co., Inc. proposes to supply the:**



956 Campus Dr. Mundelein, Illinois 60060  
Phone: 847-623-1625 • Fax: 847-623-4847  
[www.waukeganroofing.com](http://www.waukeganroofing.com) • IL License #104-000761



# WAUKEGAN ROOFING CO., INC.

- Labor, insurance, materials, tools and equipment required to remove the existing layer of roofing shingles, underlayment felts and vents down to the roof deck.
- We will remove the roofing related debris from the jobsite and properly dispose of it in a State registered landfill.
- Asphalt Saturated Felt Underlayment will be installed on the remaining roof deck not previously covered with ice and water shield
- CertainTeed Swift Start Self Sealing starter strip shingles will be installed where required.
- *CertainTeed Landmark™* Shingles with a *Limited Lifetime material warranty* will be installed along with matching *CertainTeed Shadow Ridge™* hip and ridge shingles
  
- The following products will also be installed in conjunction with the products listed above:
  - New Prefinished steel Gutter apron flashings will be installed at all the gutter edges.
  - New Prefinished steel drip edge along all rake edges.
  - New plumbing exhaust vent boots at all plumbing vent stacks.
  - New 4x4x8 flashing tins at all the roof to wall intersections.
  - Air vent ridge vent II along the ridge lines.
  
- ***CertainTeed 3-Star SureStart™ Warranty is included in this proposal.***
- ***Waukegan Roofing Co., Inc. 2-year Workmanship Warranty is included in this proposal***

**Base Proposal Price for the work described above is \$ 24,000.00 \_\_\_\_\_**

**Our Proposal is described below: Well house #5**

***Waukegan Roofing Co., Inc. proposes to supply the:***

- Labor, insurance, materials, tools and equipment required to remove the existing layer of roofing shingles, underlayment felts and vents down to the roof deck.
- We will remove the roofing related debris from the jobsite and properly dispose of it in a State registered landfill.
- New 2x6 wood nailers will be added around the perimeter edges to accommodate for the new insulation height.
- Two new Layers of 1.5" Poly ISO insulation boards will be fastened in place to the wood deck using Heavy duty insulation plates and Heavy-duty fasteners.
- New .060 EPDM single ply membrane will be adhered to the new insulation.
- New prefinished steel Drip edge will be installed around all four sides of the building

**Base Proposal Price for the work described above is \$ 15,700.00 \_\_\_\_\_**

**Our Proposal is described below: Well house # Soffit and fascia**

***Waukegan Roofing Co., Inc. proposes to supply the:***

- Labor, insurance, materials, tools and equipment required to remove the existing layer of roofing shingles, underlayment felts and vents down to the roof deck.
- We will remove the Soffit, fascia and J channel and properly dispose of it in a State registered landfill.
- Supply and install new prefinished aluminum J channel around all four sides of the well house.
- Supply and install new Solid prefinished aluminum soffit panels, approximately 90 lineal feet.
- Supply and install new prefinished aluminum Fascia, approximately 90 lineal feet.
- Supply and install new prefinished Freeze wrap, approximately 90 lineal feet.

**Base Proposal Price for the work described above is \$ 4,900.00 \_\_\_\_\_**



956 Campus Dr • Mundelein, Illinois 60060  
Phone: 847-623-1625 • Fax: 847-623-4847  
[www.waukeganroofing.com](http://www.waukeganroofing.com) • IL License #104-000761



# WAUKEGAN ROOFING CO., INC.

***This Proposal Price is based on the following:***

- ***This proposal, if accepted, is the Contract Document***
- ***The prices set forth in this proposal are good for 30 days from the date shown at the top of this page.***
- ***Prior to finalizing any proposal documents after that date may be cause for these proposed prices to be increased to reflect the additional material and transportation costs extended to the contractor.***

***Duties and Rights of Contractor:***

Waukegan Roofing Co., Inc. (herein known as contractor) duties and rights in connection with the specific project address as described on page one herein are as follows:

- Responsibility for and supervision of work:
  - The contractor shall be solely responsible for all roofing and related work described above in this contract document including the techniques, sequences, procedures and gives it all the attention necessary for such proper supervision and direction.
- Furnishing of the tools, equipment, labor and materials:
  - The contractor shall provide and pay for all tools, equipment, labor, material and all other facilities and services necessary for the proper completion of all work specified and described above in this contract document
- Clean up:
  - The contractor agrees to keep the work area and adjoining areas free of waste material and rubbish caused by their work.
  - All cleanup of roofing related debris will be contained onsite on a daily basis and properly disposed of as needed and upon completion of all work as described herein in a State Registered Landfill.
  - Contractor further agrees to remove upon completion of the project all tools, equipment and surplus materials

***Insurance:***

(A) Our standard Insurance Coverage is included as stated below:

- \$2,000,000.00 General Liability Coverage
- \$1,000,000.00 Automobile Liability
- \$10,000,000.00 Excess / Umbrella Liability
- \$ 500,000.00 Workers Compensation and Employers' Liability

(B) Contractors Liability Insurance:

- The contractor agrees to keep in force at its own expense during the entire period of time required to complete the roofing project described herein such liability insurance as described above to protect them from claims under workers compensation and other employee benefit laws, for bodily injury and death, and such property damage that may arise out of work under this contract, such insurance shall include contractual liability insurance applicable to contractors obligations under this contract. All claims of property damage must be reported to contractor within 5 days after completion of the work described in this contract.

(C) Owners Liability Insurance:

- The owner agrees to maintain in force their own liability insurance during the entire course of this roofing project and reserves the right to purchase such additional insurance as in their opinion is necessary to protect them against claims arising out of the contractors operation

(D) Property Damage Insurance on the work site:

- The owner agrees to maintain at their own expense during the entire course of this roofing project property damage insurance on the work site to its full insurable value including interests of the owner, contractor and subcontractors against fire, vandalism and other perils ordinarily included in extended coverage, losses under such insurance will be adjusted with and made payable to the owner as trustee for the parties insured as their interests appear.

(E) Waiver of work site property damage claims to extent of insurance coverage:

- The owner and contractor hereby waive all claims against each other for fire damages from other perils covered by insurance provided in subdivision (D) of this paragraph.

***Disclaimer***



# WAUKEGAN ROOFING CO., INC.

- Contractor is not responsible for its inability to perform or delays caused by acts of God, labor disputes or strikes, war, riots, weather conditions, material availability shortages, public authorities, or other cause and casualties beyond its reasonable control and delays due to owners conduct.

## **Guarantee**

- All work completed by Waukegan Roofing Co., Inc. own employees in conjunction with this contract shall be covered for a period of 2 years from the date of completion as explained and described in the Waukegan Roofing Co., Inc. Workmanship Warranty.
- The Roofing System Manufacturer (the manufacturer of the roofing materials used in the conjunction with this contract) shall issue their own Warranty to the owner as described above in the Contract document.

## **Conditions:**

- Proper, safe and adequate jobsite access shall be provided by the Authorized Signee / Owner at no cost or expense to Waukegan Roofing Co., Inc. for the duration of time as required to complete this roofing project
- All roofing related materials will be delivered to and stored on the jobsite
- Pricing for this roofing project is based on regular working hours 6:30 am through 3:00 pm Monday through Friday
- This roofing project is to be completed once started in one continuous operation weather permitting
- All existing and / or new roof penetrations, roof curbs, equipment rails and parapet walls shall be in place and 100% ready for the commencement of roofing related work prior to the start of this roofing project.
- No extra work will be completed without receiving either prior written and/or verbal approval from the Authorized Signee /Owner or Owner(s) Authorized Agents agreeing to pay for the extra work in addition to the amount(s) shown on this contract proposal.
- We have included the following OSHA exterior safety requirements designated by the "National Roofing Contractors Association" in our proposal:
  - Job appointed safety watchman
  - Warning line system (flags and standards)
  - Fall protection where required
  - Protective clothing/hardhats as required

## **Exclusions:**

- Any and all details relating to this project in any way that are shown or detailed on any plans or sketches not provided to this contractor for the preparation of this proposal
- Any and all specifications relating to this project in any way that are explained, detailed or specified on any plans or sketches not provided to this contractor for the preparation of this proposal
- Any and all requirements of the roofing system design and the requirements of the roofing system to meet the any specific Building, Construction, Energy, Green, Electrical, Plumbing and/or the new 2012 ICC Energy Code requirements are the responsibility of the Authorized Signee / Owner or a Design Professional employed by the Authorized Signee /Owner and is specifically not the responsibility of Waukegan Roofing Co., Inc.
- Any and all requirements of FM-1-52 wind uplift testing using the "bubble test" are specifically excluded and are by others at no cost or expense to Waukegan Roofing Co., Inc. and are specifically not included in this proposal price.
- Any and all plumbing, carpentry, roofing, sheet metal, roof deck, masonry or brick, electrical and HVAC work not referenced above
- Any and all additional insurance requirements not described herein
- Furnishing of any additional sheet metal flashings for skylights, roof hatches, mechanical roof mounted equipment curbs or equipment rails, portals or plumbing vent flashings not mentioned above
- Disconnection and / or reconnection of electrical, gas, HVAC condensate lines, unit heater flue pipes, flue pipes of any kind, television, telecommunication, satellite receiver or antennas of any kind not mentioned above
- Furnishing of any and all overflow drains, scuppers or conductors or downspouts of any kind not mentioned above
- Interior cleanup of any kind for any reason
- Determination of the structural slopes or the structural integrity to accept the roofing system described above
- All OSHA safety requirements for safety protection of the interior because of rooftop openings and opened roof deck above the interior work space
- Any and all demolition work not referenced above
- Testing, removal and disposal of any and all asbestos containing materials
- Building Permits, Street or Sidewalk Permits, Crane or Lifting Permits, Payment or Performance Bonds
- Snow or Ice removal



# WAUKEGAN ROOFING CO., INC.

## **Time and Material Rates/Unit Pricing for Extra Work Requested or Required and Not Specified Above**

- Waukegan Roofing Co., Inc. Employee Labor including taxes, fringe benefits, insurance, overhead and profit at \$160.00 per hour per man
- Materials at cost plus 15% markup
- Subcontractors (if any are required) at cost plus 15% markup
- Manufacturers Membrane Base Flashing at:
  - Additional Roof curbs in place at start of job: \$95.00 per lineal foot
  - New Roof curbs installed through the finished roof system: \$115.00 per lineal foot
- Roof Penetrations such as flues, portals, roof drains, waste pipes, pitch pans, etc.
  - Additional Penetrations in place at the start of job: \$195.00 per each unit
  - Penetrations installed through the finished roof system: \$350.00 per each unit
  - Manufacturers approved walk pads or equal installed: \$65.00 per each pad

**During the course of a project of this nature we sometimes uncover deteriorated roof decking or framing lumber. In the event deteriorated materials are found we will remove and replace the deteriorated materials based on the following unit prices which shall be in addition to the amount(s) shown on this contract/proposal:**

- Gypsum Roof Decking will be removed and replaced using pre-manufactured gypsum roof decking panels at: \$65.00 per square foot
- Steel Roof Decking will be removed and replaced with Galvanized/Prime Coat using (Type "A" or "B" Decking) at: \$17.50 per square foot
- Steel Roof Decking will be removed and replaced with Galvanized/Prime Coat using (Type "N" or "F" Decking) at: \$27.50 per square foot
- Plywood Roof Sheathing will be removed and replace with:
  - 1/2" Plywood Roof Sheathing at: \$8.50 per square foot
  - 5/8" Plywood Roof Sheathing at: \$9.50 per square foot
  - 3/4" Plywood Roof Sheathing at 10.50 per square foot
- 1x Standard Roof Sheathing Boards will be removed and replaced at: \$16.50 per lineal foot
- 2x Tongue and Groove Roof Decking will be removed and replaced at: \$27.50 per lineal foot
- 3x Tongue and Groove Roof Decking will be removed and replaced at: \$65.00 per lineal foot
- Structural Wood Framing and Perimeter Blocking Lumber will be removed and replaced at:
  - 2" x 4" (nominal size) at \$16.50 per lineal foot
  - 2" x 6" (nominal size) at \$16.75 per lineal foot
  - 2" x 8" (nominal size) at \$17.00 per lineal foot
  - 2" x 10" (nominal size) at \$17.50 per lineal foot
  - 2" x 12" (nominal size) at \$18.00 per lineal foot
- Exterior Wood Trim or Fascia Boards will be removed and replaced at: \$31.00 per lineal foot
- Any and all painting or staining of any kind is by others and is specifically not included

## **Payment Terms and Conditions:**

**Upon acceptance of this Proposal / Contract as written and agreed to:**

- We need to receive back in our office:
  - One complete signed and initialed copy of all of the pages of this Proposal
  - Upon receipt of the signed documents
    - We will invoice you for a Deposit which be equal to 1/3<sup>rd</sup> of the Proposal amount which will be due within 10 days of the date of the invoice
    - Upon receipt of the Deposit our office will contact you with a proposed schedule date
      - It is important to understand that schedule dates are subject to change without notice due to weather conditions and previously scheduled production schedules
- It is further understood, agreed and accepted that the balance due shown in any and all pay applications presented according to the terms defined in the contract documents including any and all agreed to extra charges will be due in full within 10 days of the date of the invoice
- It is further understood, agreed and accepted that a Service Charge of 2% per month will be added to all balances not paid within 30 days of their due date.
- If the Authorized Signee /Owner fails to pay pursuant to the Terms of this agreement and Waukegan Roofing Co., Inc. or its authorized legal representative elects to take legal action to collect any and all amounts owing, the



956 Campus Dr. Mundelein, Illinois 60060  
Phone: 847-623-1625 • Fax: 847-623-4847  
[www.waukeganroofing.com](http://www.waukeganroofing.com) • IL License #104-000761



# WAUKEGAN ROOFING CO., INC.

Authorized Signee / Owner shall pay all costs incurred by Waukegan Roofing Co., Inc., or its legal representative including but not limited to:

- Attorney's fees, court costs, depositions and transcript costs, sheriff's fees, special process server fees and bond costs
- This transaction shall be governed by the:
  - Laws of the State of Illinois
  - Jurisdiction and venue for the hearing for any matter in dispute shall be with the Lake County Circuit Court of Illinois
- The Authorized Signee / Owner by making final payment waives all claims except those arising out of
  - Faulty work appearing after substantial completion
  - Work that does not comply with these contract documents
  - Outstanding claims of lien
  - Failure of Waukegan Roofing Co., Inc. to comply with any guarantees or warranties
- All guarantees and warranties are null and void if any and all payments are not made within the contract terms and conditions as stated herein

*We want you to know that all of us at Waukegan Roofing Co., Inc. are dedicated to your total satisfaction and that we know and understand what our role is in the process of maintaining and improving your building.*

Respectfully submitted,  
Waukegan Roofing Co., Inc.

Accepted \_\_\_\_\_ 2024

*Josh King*  
Project Manager

\_\_\_\_\_  
Authorized Signee

\_\_\_\_\_  
Authorized Signee's Printed Name & Title





February 10, 2025

# Village Board Meeting Agenda Item Cover Sheet

Agenda Item: D. Public Works 5-Ton Truck Replacement Purchase

Alignment with Strategic Plan:

- C** Community Branding & Engagement
- G** Responsible Growth & Development
- F** Future Ready Operations
- I** Capital Infrastructure Planning & Improvements
- B** Business Recruitment & Retention
- U** Operational/Unaffiliated

Budgetary Impact: \$222,728 from the FY 2026 Vehicle Replacement Fund

Within Budget:  Yes  No

Suggested Motion: **Authorize the purchase of a 5-Ton Dump Truck in an amount not to exceed \$222,728.**

Voting Record:

- |                          |                   |                          |                 |
|--------------------------|-------------------|--------------------------|-----------------|
| <input type="checkbox"/> | Trustee Chybowski | <input type="checkbox"/> | Trustee Rosten  |
| <input type="checkbox"/> | Trustee Dickson   | <input type="checkbox"/> | Trustee Suchy   |
| <input type="checkbox"/> | Trustee Dunham    | <input type="checkbox"/> | Mayor Marturano |
| <input type="checkbox"/> | Trustee Grace     |                          |                 |



DATE: February 7, 2025

TO: Clay Johnson, Village Administrator

FROM: Charles Hernandez, Utility Systems Manager

RE: 5-Ton Vehicle Replacement

Public Works is requesting to enter into a sales order with Monroe and Rush Truck Center for the purchase of a heavy-duty diesel dump truck with plow accessories. As you are well aware, new vehicles are still experiencing a lag time on delivery but has seen a slight improvement. We currently have a heavy-duty diesel scheduled for replacement in FY 25/26 but it has not gone through the budget approval process. Through our communications with Rush Truck Center, we have been placed as the 39<sup>th</sup> in line for the next chassis to roll off the assembly line. The sales order will secure our place and lock us in at current pricing.

In general, manufacturers do not construct these vehicles at the same facility. You must purchase a chassis that has a delivery time of eight months and then it is delivered to the builder for assembly with an additional ten months to build. The estimated delivery time if ordered now is late 2026 to early 2027.

Our current heavy-duty diesel trucks are Internationals with a local Monroe dealer servicing them when needed. The recommended Monroe and Rush Truck Center are part of the Source Well and State Bid programs and we have purchased through both companies in the past.

The purchasing of the heavy-duty diesel vehicle in 2025/26 will meet current emissions standards. However, according to recent reports, the EPA's new diesel emissions regulations, set to take effect in 2027, are expected to significantly increase the price of heavy-duty diesel trucks, with estimates ranging from \$25,000 to \$30,000 per truck. This additional cost will need to be incorporated for future purchases for both mid-size and heavy-duty vehicle replacements.

Rush Truck Center would build the chassis at a cost of \$99,998 with Monroe building the vehicle at a cost of \$120,730. These prices are reflective of the cost from pre-COVID. Public Works is also asking for an additional \$5,000 for the placement of a plow laser to

be mounted to assist in plow placement along the shoulder/curb side of the road. The total cost is listed below:

<b>Company</b>	<b>Cost</b>
<b>Rush Truck Centers - Chassis</b>	\$96,998
<b>Monroe - Build</b>	\$120,730
<b>Plow Laser</b>	\$5,000
<b>Total</b>	<b>\$222,728</b>

With your permission, we would like to enter into a sales agreement with Monroe and Rush Truck Center for the purchase of a heavy-duty diesel vehicle with a scheduled delivery of 26/27.





a brand of aebi schmidt

1051 W 7th St  
Monroe, WI 53566  
Sales Rep: Tim Reynolds  
Ph: 815-275-0223  
www.MonroeTruck.com

J.O. #

Quotation ID: 9KK1000767  
Date: 1/15/2025  
Valid thru: 2/14/2025  
Terms: NET 30  
Quoted by: Kaden King  
Ph/Fax: 608-329-8322 /



Quoted to:

LINDENHURST,VILL OF (ATTN: )  
2301 E SAND LAKE RD  
LINDENHURST, IL 60046  
Ph: 847-356-8252 / Fax: 847-356-8270  
Email:

Chassis Information

Year: 2019	Make: INTERNATIONAL	Model: WORK STAR	Chassis Color: SCHOOL BUS	Cab Type:
Single/Dual: DRW	CA: 102.0	CT:	Wheelbase:	Engine: DIESEL
			F.O. Number #:	Vin:

Monroe Truck Equipment, Inc. is pleased to offer the following quote for your review:

Description	Amount
<b>10' 5-6 YARD CRYSTEEL STAINLESS STEEL GLADIATOR DUMP BODY</b>	
- 201 STAINLESS STEEL CONSTRUCTION ABOVE THE FLOOR	
- SIDES: 26", 7GA	
- FRONT: 48", 7GA	
- REAR : 36", 7GA	
- FLOOR: 3/16" AR400 9" RADIUS	
- MATERIAL: 7GA. STAINLESS STEEL	
- WESTERN UNDERSTRUCTURE	
- SLIDE OUT LADDER AND GRAB HANDLE RIGHT SIDE OF BODY	
- SPRING LOADED SHOVEL HOLDER; STAINLESS STEEL	
- 1/2 X 7 GA. X 84" CAB SHIELD 100% WELDED	
- REFLECTIVE TAPE ACROSS THE BACK OF THE CAB AND SIDES OF BODY	
- SELF ADJUSTABLE 87-107 DB BACKUP ALARM	
- RECESSED LED S/T/T AND BACKUP LIGHTS WITH SEALED WIRE HARNESS	
- RUBBER REAR FLAPS	
- SLIDING PATCHGATE	
<b>CRYSTEEL RC750 SUBFRAME HOIST</b>	
- 17.2 TON CAPACITY	
- 2000 P.S.I.	
- FULLY GREASABLE HINGE AND ROLLERS	
- DOUBLE ACTING	
<b>PULL TARPS MANUAL TARP SYSTEM</b>	
- SPRING LOADED ALUMINUM ROLLER (REWINDS TARP)	
- STEEL HOUSING PROTECTOR	
- EXPANDED ASPHALT TARP WITH SIDE FLAPS	
- TARP TAMER TO HOLD FRONT OF TARP DOWN	
- INSTALLED	
<b>PINTLE HOOK W/MOUNTING, 50 TON</b>	
- PREMIER 2200 PINTLE HOOK	
- MANIFOLD, PINTLE PLATE MOUNTED	
<b>CAMERA</b>	
- HEATED BACK UP CAMERA (MUST CONFIRM REVERSE ACTIVATED OR ON ALL TIME)	
- USING 6100 SPREADER CONTROL HEAD FOR DISPLAY	
<b>PRE-WET SYSTEM</b>	
- SINGLE 240 GAL BEHIND CAB TANK FORCE CONTROL	
<b>LIGHTS - WHELEN, JUSTICE SUPER LED ILL STROBE SYSTEMS, 72" LIGHT BAR</b>	
- 72" JUSTICE LED LIGHT BAR MOUNTED ON ROOF	
- LED S/T/T MOUNTED IN REAR POST, PINTLE PLATE AND ON TOP OF CAB SHIELD	
- LED BACK UP LIGHT MOUNTED IN REAR CORNER POST	
- 2 AMBER AND 1 CLEAR STROBE INSTALLED OUTSIDE THE CORNER POST ON EACH SIDE	
- 2-YEAR WARRANTY	



**Description****Amount****PTO, HOTSHIFT, ROTATABLE FLANGE; NEW WORLD TRANSMISSON; INSTL**

- FORCE AMERICA TXV92-RH W/FITTING KIT
- 5.6 CUBIC INCH 92CC LOAD SENSE
- 24 GPM FLOW @ 1000 RPM
- 5,000 PSI OPERATING PRESSURE
- DIN 5462 - 4 BOLT FLANGE MOUNT
- 6100 ULTRA 2 STICK CONTROLER W/ROAD WATCH DISPLAYED ON CONTROL
- TANK, 30 GAL. STD., FRAME MOUNT, W/FILTRATION, MILD STEEL; INSTL

**FORCE ADD-A-FOLD VALVE ASSEMBLY**

- ENCLOSURE, FRAME MOUNT, MILD STEEL; INSTL
- DA - HOIST W/500 PSI DOWNSIDE RELIEF
- DA - PLOW LIFT
- DA - PLOW ANGLE
- 14GPM AUGER
- 7GPM SPINNER
- 7GPM PRE-WET

**OPTIMO OP-31-IR CAMERA FOR FORCE AMERICA 6100 SPREADER CONTROL (GEN 5 ONLY)****TRUCK PORTION - FLAT-FOLD LIFT ARM HITCH W/ INTEGRAL QCP RECEIVER**

(REQUIRES MINIMUM OF 18" FRONT FRAME EXTENSION)

**MPPJ45R12-ISTT; 12' TORSION TRIP "J" STYLE REVERSIBLE POLY PLOW**

- 3/8" POLYMER MOLDBOARD WITH INTEGRAL SHIELD
- (10) 1/2" ONE-PIECE FLAME CUT RIBS
- 2" X 3" X 3/8" TOP ANGLE
- 4" X 4" X 3/4" BOTTOM ANGLE
- (6) ADJUSTABLE 3/4" TORSION TRIP SPRING ASSEMBLIES FOR A TWO-SECTION TRIP
- 5/8" X 8" ONE-PIECE CENTER PUNCH CUTTING EDGE
- 4" X 4" X 3/8" CROSS-TUBE SUPPORT
- 3-1/2" X 3-1/2" X 1/2" SEMI-CIRCLE
- (2) 3" X 10" DOUBLE ACTING REVERSE CYLINDERS WITH CUSHION VALVE
- BUILT-IN MONROE LEVEL LIFT ASSEMBLY
- MOLDBOARD AND PUSHFRAME TO BE 100% CONTINUOUSLY WELDED
- MOLDBOARD POWDER COATED ORANGE
- PUSH FRAME POWDER COATED BLACK
- WRAP-AROUND CURB GUARDS
- 12' CARBIDE CUTTING EDGE W/COVER BLADE; 3/4" X 6"; N/A SLOT TRIP
- 36" FLUORESCENT ORANGE FLEXIBLE PLASTIC MARKERS
- SCREW ADJUSTABLE PARK JACK; S&I INSTALLE
- 12' RUBBER SNOW DEFLECTOR
- MAILBOX CUT OUT ON RT SIDE
- QCP LOOP HITCH (WELDED ON TYPE) PLOW PORTION

**MS966RF REV FLIGHT SPREADER, 96" WIDE, 201SS, DIRECT DRIVE, LEFT DISCHARGE**

- 201 STAINLESS STEEL CONSTRUCTION
- DIRECT DRIVE
- 7 GA. TROUGH
- 1/4" END PLATES
- FULL OPENING TOP AND BOTTOM CLEAN-OUT DOORS
- 6" AUGER DIAMETER
- QUICK DETACH MOUNTING BRACKETS
- TAILGATE SHIELDS
- BARE STAINLESS STEEL (NOT PAINTED)
- APPLICATION RATE SENSOR INSTALLED IN AUGER MOTOR
- STAINLESS STEEL SELF LEVELING SPINNER WITH POLY DISC
- INSTALLED

Quote Total: \$120,730.00

**\*\* DUE TO CURRENT MARKET CONDITIONS, IF THE CHASSIS WILL NOT BE ON-GROUND AT MONROE TRUCK EQUIPMENT WITHIN 240 CALENDAR DAYS OF ORDER DATE, WE WILL REQUIRE A MINIMUM 50% DOWN PAYMENT BEFORE THE 210<sup>TH</sup> DAY. IF YOU ARE NOT ABLE TO PROVIDE A DOWN PAYMENT, YOUR MUNICIPALITY COULD BE SUBJECT TO A MINIMUM OF 3% - 5% PRICE INCREASE ON BID PRICE AT TIME OF INVOICE!**

Down Payment Due Date: \_\_\_\_\_



**Additional Options:**

Description	Amount	Add to quote? Yes / No
-------------	--------	---------------------------

**Terms & Conditions**

- Terms are Due Upon Receipt unless prior credit arrangements are made at the time of order.
- Please note if chassis is furnished, it is as a convenience and terms are Net Due on Receipt of Chassis.
- State and Federal taxes will be added where applicable. **Out-of-state municipal entities may be subject to Wisconsin sales tax.**
- Restocking fees may be applicable for cancelled orders.
- MTE is not responsible or liable for equipment that does not meet local/state regulations if those laws are not made known at time of order.

By signing and accepting this quote, the customer agrees to the terms listed above and has confirmed that all chassis information listed above is accurate to chassis specs.

<b>Re-Assign (Required for all pool units):</b> <input type="checkbox"/> Fleet <input type="checkbox"/> Retail	<b>MSO/MCO (ONLY check if legally required):</b> <input type="checkbox"/> MCO <input type="checkbox"/> MSO		
Customer Signature:	<table border="1" style="width: 100%;"> <tr> <td style="width: 50%;">Customer P.O. Number:</td> <td style="width: 50%;">Date of Acceptance:</td> </tr> </table>	Customer P.O. Number:	Date of Acceptance:
Customer P.O. Number:	Date of Acceptance:		

